

# PHOTOTROPY

LYMAN CHALKLEY, JR.

*The Pennsylvania State College, State College, Pennsylvania<sup>1</sup>*

## CONTENTS

Introduction.....	218
Experimental observations.....	221
Phototropy in liquid systems.....	221
Lists of phototropic liquids.....	221
The color change in liquids.....	225
The exciting light.....	225
The color produced.....	226
Phenomena accompanying the phototropic change.....	227
Change in optical rotation.....	227
Change in conductivity.....	227
Fatigue.....	229
Phototropy in solid systems.....	230
Lists of phototropic solids.....	230
The color change.....	249
The exciting light.....	250
The reversing light.....	252
The influence of temperature.....	253
The photoelectric effect.....	256
Energy relationships.....	259
Chemical relationships.....	262
Fatigue.....	264
Theoretical.....	265
The phototropy of dye derivatives.....	265
The phototropy of camphor derivatives.....	266
The phototropy of triphenyl methane derivatives.....	267
The phototropy of ferrocyanide solutions.....	267
The phototropy of lithopone.....	267
The phototropy of lithium imide.....	268
The phototropy of mixed mercurous and silver iodides.....	268
The phototropy of stilbene derivatives.....	268
Fulgides, anils, hydrazones, osazones and $\beta$ -tetrachloro- $\alpha$ -ketonaphthalene.....	269
Physical theories.....	270
Chemical theories.....	271
Discussion.....	274
References.....	277

---

<sup>1</sup> Present address: Pedlar and Ryan, 250 Park Avenue, New York City.

## INTRODUCTION

"The first observation was that a gate post painted white by means of a new pigment having a zinc basis appeared black all day and white all night, turning black again soon after sunrise, *et ainsi de suite* for any number of days" (82).

Mr. Thomas Griffiths, F.C.S., the possessor of this remarkable gate post, very naturally exhibited it to his friend, Dr. T. L. Phipson, who had written a book on phosphorescence, and who proceeded to write about the gate post.

As a result of Dr. Phipson's writings, which appeared in 1881, the matter came to the attention of the manufacturer of the "new pigment having a zinc basis," who divulged the information that Mr. Griffith's post was not nearly so original as it was considered; that he had been familiar with this property of lithopone for ten years, and that it had caused a great deal of trouble in his business. He added that he had recently supplied Mr. Griffiths with paint that would stay unblushingly white no matter how great the illumination. As the manufacturer's note appeared in 1881 the property of lithopone to undergo a reversible color change induced by light was probably first recognized about 1870 (61).

Mr. Griffiths's gate post received a certain amount of publicity in 1881 and even as late as 1891 (12), and its peculiar behavior led Dr. Phipson to suggest that lithopone might contain a new element, for which he proposed the name "Actinium," though, unfortunately, he endowed it with properties totally different from those of the actinium of today (83). However, it was not recognized that the color change exhibited by certain samples of lithopone might be a phenomenon common to a variety of substances rather than due to the presence of a hypothetical new element, and the observation of ter Meer (117), published five years before Phipson's first paper, that the potassium salt of dinitroethane underwent the same sort of color change, remained unnoticed. Therefore, Mr. Griffiths's post continued an isolated wonder until it was forgotten.

In 1899 Marckwald (47) observed that two different organic compounds, anhydrous quinoquinoline hydrochloride and  $\beta$ -

tetrachloro- $\alpha$ -ketonaphthalene, became colored when exposed to light, and that they lost this light-induced coloration when placed in the dark. He recognized that this reversible color change characterized a new phenomenon, and considered it an instance of a truly reversible photo-reaction. He introduced the term "phototropy" to cover, apparently, reversible photo-reactions in general. The use of "phototropy" in this sense has not been retained, but it has been generally adopted to designate the phenomenon of a color change induced by light and reversing in the dark. The choice of the word is, perhaps, not happy. Not only has it been in use by biologists for many years in connection with color adaptations of living organisms but the form of the word does not suggest to the English-speaking scientists that it refers to a phenomenon rather than to a field of knowledge. However, the term has become well established.

An exact definition of phototropy as it may now be strictly considered is difficult to formulate. It is to be hoped that further investigation will make it possible to restrict the term to a fundamentally new phenomenon. Since the term "Phototropy" was first proposed investigators have felt that the reversible light-induced color changes exhibited by tetrachloro-ketonaphthylene, certain anils, hydrazones, osazones and fulgides formed a coherent group of phenomena, and might be considered truly phototropic. It is difficult, however, to find a single distinguishing characteristic in the phenomena exhibited by these substances. Perhaps the most striking feature is that these color changes are true adaptations; that high frequency light causes the substances to absorb light of longer wave length, while low frequency light, which is absorbed by the new absorption bands, causes the reverse color change. There are exceptions to this criterion, but it is the best now available. (See reference 104 for a further discussion.)

As the mechanism of the phototropic reaction shown by these substances is not clearly understood, and as it is not known in certain cases whether or not a substance is phototropic in the restricted sense referred to, the term is given a broad interpretation in this review. Reversible, light-induced color changes generally are discussed. These, whether or not they may be truly

phototropic in a strict sense, are all suggestive and of interest to anyone concerned with phototropy.

Simultaneously with Marckwald's discovery Biltz observed the phototropy of benzaldehyde-phenylhydrazone and certain osazones (6, 7, 8). It is curious to note that both Emil Fischer, who discovered benzaldehyde-phenylhydrazone (20), and Zincke, who discovered the chloronaphthalene derivative (133), observed the color change produced in these substances by light but failed to notice the reverse change which took place in the dark.<sup>2</sup>

Since these first discoveries, a great number of other phototropic substances have been found, and at the present over two hundred are known. Most of these substances are organic, although some are inorganic; and most phototropic substances exhibit phototropy only in the solid state. In the last few years a number of substances have been discovered to exhibit phototropy in solution, and with one possible exception, these compounds are not known to be phototropic in the solid phase.

There is a long known class of compounds the members of which show a color change when exposed to light and revert to their original color in the dark. These are the phosphorescent substances. As these substances absorb light they begin to reemit light. Therefore, when a phosphorescent substance is brought from the dark into the light the color of the substance changes until an equilibrium is reached between the rates of light absorption and light emission. This "saturation" of absorption bands has been known and studied for some time, but the substances themselves have never been considered as phototropic. We know very little about the relationships between the mechanisms of phosphorescence and phototropy, and therefore the exclusion of phosphorescent substances from classification as phototropic may be arbitrary and superficial. However, if only because of practical limitations of space, the present review must be limited to the behavior of phototropic substances whose color change is not due directly to the re-emission of absorbed light. As a matter of fact, both zinc sulfide and the alkaline earth sulfides do show phototropy,

<sup>2</sup> However Wislicenus noticed that the color change of benzaldehyde phenylhydrazone was reversible (*Ann.*, 277, 366 (footnote) (1893)).

but in this the color change is of the opposite sign from that caused by saturation of the phosphorescent absorption bands.

Even excluding the phosphorescent materials, phototropy remains a diversified phenomenon. It is exhibited by pure substances, by liquid and solid solutions, and possibly by mixtures. A number of theories have been advanced to account for the various manifestations of phototropy. Such a plurality of theories may be justified since it is possible that in different cases totally different mechanisms may be involved, and consequently that no general explanation could be formulated. But even the illumination afforded by the individual theories leaves certain phases of phototropy obscure, and we are in no position to start with one, or several, generalizations and derive the known facts of the phenomenon.

Therefore the following review will be divided into two parts so as to present first the experimental data, and then the theories which have been proposed to account for the observed facts.

#### PART I. EXPERIMENTAL OBSERVATIONS

##### *Phototropy in liquid systems*

Except for non-crystalline solids, which in this review are classified as solids rather than liquids, all of the known phototropic liquids are solutions. The phototropy of these solutions is dependent on the nature of both the solute, which may be considered as carrying the phototropic properties, and on the solvent. While the color developed is apparently independent of the nature of the solvent, the intensity of the color developed is very greatly dependent on the solvent.

##### *Known phototropic liquids*

*Dye derivatives.* Most of the known phototropic liquids are solutions of colorless derivatives of basic triphenylmethane dyes. The cyanides, carbinols, and sulfites of various of these dyes have been found to be phototropic in solution. The solutions are colorless, or faintly colored, in the dark, but acquire the color of the parent dyestuff on exposure to light. The constitutions as-

cribed to these derivatives may be exemplified by the structures of those derived from pararosaniline which are given below:

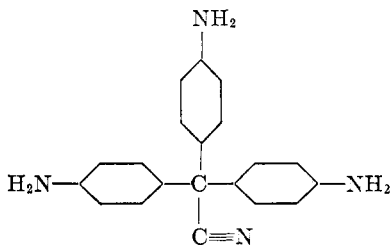

Pararosaniline cyanide

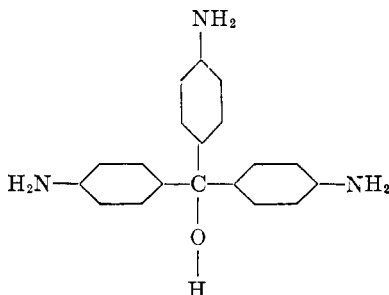

Pararosaniline carbinol

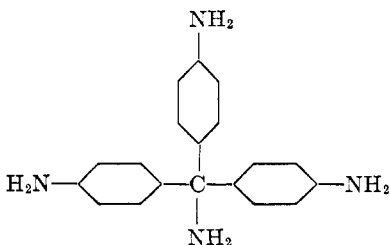

Pararosaniline amine base (125)

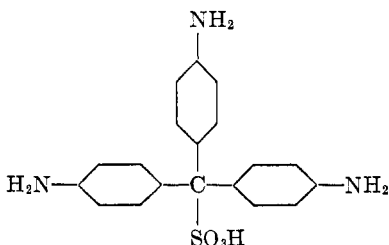

Pararosaniline sulfite

The formulas represent the colorless forms, and the word "leuco" is sometimes introduced into the names of these compounds, as "pararosaniline *leuco* cyanide," to emphasize their colorless state. But this seems hardly necessary, since presumably the isomeric colored derivatives are not stable under ordinary conditions.

The solutions which contain dyestuff derivatives and are known to be phototropic are the following:

*Cyanides:*

Pararosaniline cyanide	} Solvents: ethyl alcohol (42), ethyl ether, benzene (36)
Crystal violet cyanide	
Malachite green cyanide	
Brilliant green cyanide	
Auramine cyanide	
Benzaurine cyanide	} Solvents: Water, or aqueous alcohol, containing KCN (43)
Phenolphthalein cyanide	

*Carbinols:*

Malachite green carbinol	} Solvents: ethyl alcohol made alkaline with KOH (42, 44); benzene (36)
Crystal violet carbinol	
Benzaurine carbinol	} Solvents: Water, or aqueous alcohol, containing KOH (43)
Phenolphthalein carbinol	

*Amine Bases:*

The amine base of malachite green in benzene or in ethyl alcohol containing ammonia becomes colored green under the influence of light. The amine base of crystal violet in the solvents just mentioned and in ethyl ether also becomes colored in light. From the author's description it is uncertain whether or not these solutions lose their color, or even a part of it, on standing in the dark. It is, therefore, uncertain whether they are phototropic or not (36, 43).

*Sulfites:*

- Pararosaniline hydrochloride sulfite in water containing sulfur dioxide (36, 44)
- Rosaniline sulfite in water containing sulfur dioxide (34)
- "Methyl violet" sulfite in water containing sulfur dioxide (34)
- Crystal violet sulfite in water containing sulfur dioxide (34)
- Malachite green sulfite in water containing sulfur dioxide (34)

The following solutions of related substances have been examined and found to be not phototropic (36):

- Sulfite of brilliant green
- Sulfite of brilliant green sulfate
- Victoria blue cyanide

In view of later work the impossibility of obtaining phototropic solutions of brilliant green sulfite is doubtful (34, 43).

*Camphor derivatives.* The three substances listed below form phototropic solutions in chloroform (105). The color of the solutions in the dark is indicated for each compound. The color produced by light is green in all three cases. The compounds are:

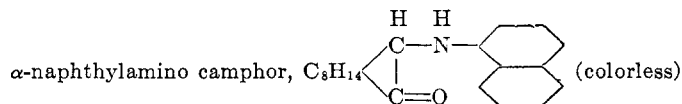

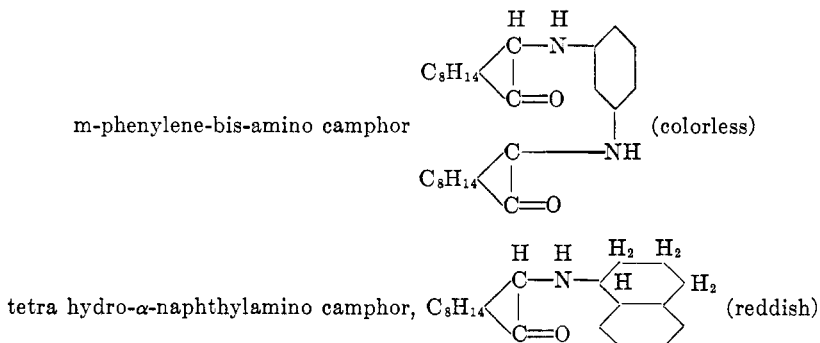

*Other solutions.* 10·10'-dihydroxy-diphenanthryl-9,9'-amine,

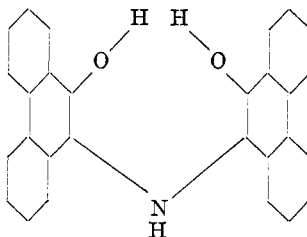

is phototropic in ethereal solution (92). The solution is brownish red in the dark and becomes bright yellow on exposure to sunlight. This is the first instance so far mentioned in which light causes a reversible fading of color rather than a deepening of color.

A benzene solution of equal molecular proportions of diphenyl-monobiphenylmethane and diphenyl-monobiphenyl methyl chloride when placed in a sealed tube and exposed to sunlight acquires a reddish color, visually similar to the color of benzene solutions of diphenyl-monobiphenyl-methyl (91). In the dark the solution loses its reddish color, and returns to its colorless condition. Likewise a benzene solution of equivalent amounts of phenyl-dibiphenyl-methane and phenyl-dibiphenyl-methyl chloride becomes colored in the light, the color being apparently that of phenyl-diphenyl-methyl (91).

An aqueous solution of potassium ferrocyanide which contains a little phenolphthalein turns red in the light, and regains its original yellow color in the dark (4).



A solution of molybdenum trioxide in selenium oxychloride is normally light yellow but becomes indigo blue in sunlight and yellow again when placed in the dark or warmed (40).

Benzaldehyde phenylhydrazone, and probably certain others show transient phototropic properties in benzene solution when exposed to air (22). The color changes are, no doubt, intermediate stages in an irreversible oxidation (116). A similar phenomenon has long been known to take place with partially oxidized photographic developers made of ferrous oxalate.

#### *The color change*

*The exciting light.* The excitation of the phototropic change follows the Grotthus law (109, 110, 111, 112, 114, 128), and only light absorbed by the phototropic substance is active in producing a color change. The phototropic dye and camphor derivative solutions are colorless, or nearly so to the eye, and it is known that the exciting light is ultra-violet.

In some cases it is mentioned that the phototropic change is not produced by light transmitted by glass, while it is produced by light transmitted by quartz. Usually no direct determination of the active wave lengths has been made. The dye sulfite solutions appear to be the only ones which consistently require light of shorter wave lengths than is transmitted by glass (34).

The ultra-violet absorption spectra of some of the dye cyanide, amine base and carbinol solutions have been determined, but it is not known whether all or only a part of the absorbed wave lengths is active in producing the color change (36).

In considering the relationship between the magnitude of the color change, and the intensity of the light and the time of exposure to light it will be seen that the color change will not indefinitely increase in magnitude as the exposure is prolonged, but that an equilibrium point will be reached beyond which further exposure will not produce a further color change. There are two opposing reactions to be considered: first, the formation of color, or in a few cases, the bleaching caused by the action of light; and, second, the opposed "dark" reaction which destroys the color formed by light or restores the color destroyed by light.

Of course, this reverse reaction does not take place unless the "light" reaction has preceded it. This reverse reaction takes place in the light as well as in the dark, and, in the case of solutions, its rate does not appear to be directly influenced by the action of light.

Therefore, the speed with which the equilibrium point is reached, and the magnitude of the color change which the solution undergoes should bear some direct relation to the intensity of the light for any given frequency. That there is some such relationship seems to be the case, but the only attempt to make a quantitative examination of the relation for phototropic solutions was an approximate determination of the variation of the color produced in a rosaniline sulfite solution when the intensity of the white light employed was varied. The conclusion reached was that the intensity of the color at the stationary point was directly proportional to the intensity of the exciting white light (34).

*The color produced.* The color produced by the action of light on alcoholic solutions of pararosaniline cyanide was spectroscopically examined and compared with the color of pararosaniline chloride. The conclusion was reached that the two colors were identical (36, 42, 44). In the same way the colors of a light stimulated solution of rosaniline sulfite and rosaniline chloride were compared, and the conclusion was also the two colors were identical (34). There appear to have been no exact observations on the color produced by light in phototropic solutions of substances other than the dyestuff derivatives.

The intensity of color produced in solutions of dyestuff derivatives varies not only with the intensity of the exciting light, but also with the concentration of the photoactive solute and the presence or absence of other substances in solution. With rosaniline sulfite the color produced appears to be directly proportional to the concentration of the dyestuff derivative, other factors remaining constant (34). The color varies greatly with the concentration of sodium sulfite or bisulfite in the solution (34).

The addition of potassium cyanide to alcoholic solutions of the dye cyanides reduces the intensity of color which can be produced by light, and it further greatly accelerates the dark reaction so

that the fading of the color produced by light may take minutes instead of hours or weeks. Potassium hydroxide has a similar effect upon alcoholic solutions of the carbinols (36, 42, 44).

The velocity with which color is formed by the action of light on certain solutions of rosaniline sulfite has been roughly determined and plotted (34).

Working with solutions of malachite green carbinol, Ariga (2) found that the velocity of the color change was directly proportional to the intensity of the light and independent of the temperature and the concentration of alkali.

The work to be described below upon the variation of the conductivity of solutions of dye cyanides and carbinols is probably an indirect determination of the velocity of coloration.

The actual time required for the development of an appreciable color change when a phototropic solution is exposed to light varies with the solution, and, of course, with the conditions of illumination; however, it is seldom over two minutes in bright sunlight.

#### *Phenomena accompanying the phototropic change*

*Optical rotation.* A solution of 0.726 gram of  $\alpha$ -naphthylamine camphor in 100 cc. of chloroform showed a specific rotation of the mercury green line 5461 A. of  $126^\circ$ . When exposed to sunlight for six minutes, the solution changed from colorless to deep green, and the specific rotation changed to  $186.6^\circ$ . When placed in the dark after this exposure, the color of the solution faded, and the angle of rotation decreased. It is said that the change in the dark required days, and as further data are not given, it seems possible that the reverse reaction was not followed through and that it is not certain that the solution reverts to its original rotation (106).

*Conductivity.* When phototropic solutions of dye cyanides and carbinols in alcohol are exposed to light, the conductivity of the solutions increases. When the light is shut off the conductivity falls again (36, 44). Details of typical cases of this very interesting parallelism are shown in tables 1 and 2.

The measurements shown in table 1 are on a  $N/1000$  solution

of malachite green cyanide in absolute alcohol. The conductivity was measured at 25°. The light source was a mercury quartz

TABLE 1  
*Specific conductivity of malachite green cyanide (36, 44)*

	<i>k</i>
Original solution.....	$3.5 \times 10^{-7}$
After illumination with a quartz lamp for 2 hours.....	$35 \times 10^{-7}$
In the dark:	
After 2 minutes.....	$31 \times 10^{-7}$
After 5 minutes.....	$27 \times 10^{-7}$
After 41 minutes.....	$14 \times 10^{-7}$
After 46 minutes.....	$13 \times 10^{-7}$
After 51 minutes.....	$12 \times 10^{-7}$
After 2 hours and 49 minutes.....	$6 \times 10^{-7}$
After 2 hours and 59 minutes.....	$5 \times 10^{-7}$
After 4 hours and 50 minutes.....	$4 \times 10^{-7}$
After 5 hours and 0 minutes.....	$4 \times 10^{-7}$
After 23 hours and 45 minutes.....	$3 \times 10^{-7}$
After 51 hours and 15 minutes.....	$3 \times 10^{-7}$

TABLE 2  
*Specific conductivity of pararosaniline cyanide (36, 44)*

	<i>k/10<sup>-7</sup></i>
After illumination with an iron-nickel arc, 1 hour.....	18
After illumination with an iron-nickel arc, 1½ hours.....	27
After illumination with an iron-nickel arc, 2 hours.....	41
In the dark after 19 hours.....	37.5
After additional illumination with the arc, 20 minutes.....	48.5
After additional illumination with the arc, 45 minutes.....	53
After additional illumination with the arc, 1½ hours.....	72.5
In the dark for an additional 66 hours.....	51
After additional illumination for 1½ hours.....	70.5
After additional illumination for 2½ hours.....	100
In the dark for an additional 18 hours.....	68
After additional illumination for ¾ hour.....	82.5
After additional illumination for 3¼ hours.....	86.5
After additional illumination for 4½ hours.....	91
After an additional 106 days in the dark.....	52.5

lamp, and the temperature of the solution was 12° during the illumination.

In table 2 are shown the conductivities at 25° of a N/1000 solution of a pararosaniline cyanide in absolute alcohol. The light source was an iron-nickel arc, and the temperature of the solution during the exposure to light was 12°.

The conductivity of alcohol used as the solvent was  $3 \times 10^{-7}$  to  $7 \times 10^{-7}$ .

The figures given for malachite green cyanide are all that could be desired for a reversible reaction, and similar results were obtained for brilliant green cyanide. The data on the carbinols of malachite green and crystal violet are not so conclusive since the conductivities of their solutions increased on merely standing in the dark, but it would seem that the high conductivity produced by light was completely lost on standing in the dark.

With the pararosaniline cyanide it will be noticed that the specific conductivity after exposure to light never reverts to anything like its original value. The same is true of the specific conductivities of the solutions of the cyanides of crystal violet and auramine. The alcoholic solution of victoria blue cyanide, which becomes colored in the light but does not fade in the dark, shows a specific conductivity which steadily increases with the exposure to light, and shows no falling off when the solution is placed in the dark.

*Fatigue.* The ethereal solution of 10,10'-dihydroxy-diphenanthryl-9,9'-amine after long exposure to sunlight remains bright yellow and will no longer become brownish red in the dark (92). There are no further data to show the nature of the change which has taken place. For want of further information we may refer to it as "fatigue."

An alcoholic solution of pararosaniline cyanide which contains potassium cyanide shows a somewhat similar behavior. Such a solution contained in a sealed tube becomes brownish and loses its phototropic properties when exposed to daylight, even in Chicago, for a few weeks.

On the other hand, the selenium oxychloride solution of molybdenum trioxide is very stable to light, and sealed tubes of this solution have been exposed to light for over eight years without diminution of the power to change color (49).

*The phototropy of solids*

Most of the work which has been done upon phototropy concerns solid systems, and has been largely devoted to a search for phototropic substances. This search has been carried on primarily by four groups of scientists; Padoa and his collaborators in Italy; Senier and his pupils in England; Stobbe in Germany; and Mourelo in Spain. In recent years a number of phototropic substances have been discovered in India. Isolated discoveries of phototropic substances have been made by other workers. Critical investigations of the phenomenon itself have been carried on especially by Chattaway, Padoa, Stobbe, and Weigert.

*The known phototropic solids*

In this section will first be listed the known phototropic organic compounds; then the inorganic systems.

There is a dearth of quantitative information on the rate with which phototropic solids undergo their color changes. But for the benefit of those who have not had practical experience in this field, it may be said that the time required for bright sunlight to produce a pronounced color change is of the order of from a few seconds to many minutes. The reverse change in the dark at room temperature requires from a minute or two to several weeks.

*Anils.* The condensation products of aldehydes and primary amines, which are variously known as Schiff bases or anils, have the general formula,  $R - CH = N - R'$ ; in which R and R' are organic radicals. A typical anil is salicylidene aniline, whose formula is given below:

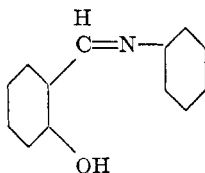

About 275 anils have been examined for phototropy, and some twenty-two have been found to be phototropic. The phototropic anils are colorless or light yellow when unaffected by light, and red or brownish red in sunlight.

TABLE 3  
The phototropic anils

AMINES	ALDEHYDES			
	Salicylaldehyde	o-Nitro- benzaldehyde	p-Hydroxy- benzaldehyde	2-Hydroxy-3- methoxy- benzaldehyde
		(96)	(97)	(103)
Aniline .....	+ (101)	-	-	-
o-Toluidine.....	-	-	-	-
m-Toluidine.....	+ (101)	-	-	-
p-Toluidine.....	-	-	-	-
o-Chloroaniline.....	+ (102)	+	-	-
m-Chloroaniline.....	- (102)	+	-	-
p-Chloroaniline.....	- (102)	-	-	-
o-Bromoaniline.....	+ (81)	-	-	-
m-Bromoaniline.....	+ (103)	-	-	-
p-Bromoaniline.....	+ (81)	-	+	-
o-Phenylenediamine.....	- (103)†	++	-	-
m-Phenylenediamine.....	+ (103)	-	-	-
p-Phenylenediamine.....	- (102)	-	-	-
m-Aminophenol.....	- (102)	-	-	-
o-Anisidine.....	+ (103)	-	+	-
m-Anisidine.....	- (103)	-	-	-
p-Anisidine.....	+ (103)*	-	-	-
p-Phenetidine.....	- (24)	-	-	-
p-Aminobenzaldehyde.....	- (24)	-	-	-
o-Aminobenzoic acid.....	- (24)	-	-	-
m-Aminobenzoic acid.....	+ (81)§	-	-	-
p-Aminobenzoic acid.....	+ (102)	-	-	-
p-Amino-methylbenzoate.....	- (24)	-	-	-
p-Amino-ethylbenzoate.....	+ (24)	-	-	-
o-Aminocinnamic acid.....	+ (24)	-	-	-
Xylidine (NH <sub>2</sub> :CH <sub>3</sub> :CH <sub>3</sub> :1:2:4).....	- (101)	+	+	-
Xylidine (NH <sub>2</sub> :CH <sub>3</sub> :CH <sub>3</sub> :1:2:5).....	- (101)	-	-	+*
Xylidine (NH <sub>2</sub> :CH <sub>3</sub> :CH <sub>3</sub> :1:3:4).....	+ (102)	-	-	-
Xylidine (NH <sub>2</sub> :CH <sub>3</sub> :CH <sub>3</sub> :1:3:5).....	- (102)	-	-	-

\* Phototropic only at low temperatures.

† Monosalicylidene-o-phenylene diamine is phototropic at low temperatures (24).

‡ The monosalicylidene compound is not phototropic. The disalicylidene compound has not been investigated.

§ Gallagher reports that this is not phototropic (24), but Stobbe made some quantitative measurements of its phototropic properties.

TABLE 3—Continued

AMINES	ALDEHYDES			
	Salicylaldehyde	o-Nitro-benzaldehyde	p-Hydroxy-benzaldehyde	2-Hydroxy-3-methoxy-benzaldehyde
		(96)	(97)	(103)
4-Cumidine.....	- (101)	-		
Mesidine.....	- (102)			
m-Nitroaniline.....	- (24)			
p-Nitroaniline.....	- (24)			
Nitro- $\psi$ -cumidine.....	- (24)			
$\alpha$ -Naphthylamine.....	- (101)	-	-	
$\beta$ -Naphthylamine.....	+ (102)	-	-	-
$\alpha$ -Chloro- $\beta$ -naphthylamine.....	- (24)			
1:2-Naphthalene diamine.....	- (24) †			
1:4-Naphthalene diamine.....	- (24)			
1:5-Naphthalene diamine.....	- (24)			
1:8-Naphthalene diamine.....	- (24)			
2:7-Naphthalene diamine.....	- (24)			
Benzidine.....	- (24)	-		
4,4'-Diamino-2,2'-dimethyldiphenyl.....	- (24)			

† The monosalicylidene compound is not phototropic either (24).

In table 3 are listed all of the known phototropic anils. In this table the anils are indicated by the aldehyde and primary amine from which they are formed. It will be seen that all the phototropic anils are derived from four aldehydes; salicylaldehyde, o-nitro-benzaldehyde, p-hydroxybenzaldehyde, and 2-hydroxy-3-methoxy-benzaldehyde. With the exception of a few salicylaldehyde derivatives described by Gallagher (24) this table lists not only the phototropic anils but all of the anils derived from the four aldehydes which have been studied for phototropy.

In the table a plus sign means that the anil is phototropic, a minus sign that it is not phototropic. A blank space indicates that the anil has not been examined for phototropy. The numbers in brackets indicate the references in which the anils are described. When an anil is derived from a diamine, the data



given in the table refer to the anil formed by the condensation of one molecule of diamine and two molecules of aldehyde. If the anil formed by the condensation of one molecule of a diamine with one molecule of an aldehyde has been studied, it is referred to in the footnotes.

In addition to the substances listed in the table a number of anils derived from benzaldehyde, cinnamic aldehyde, m-nitrobenzaldehyde, p-nitrobenzaldehyde, m-hydroxybenzaldehyde, o-methoxy-benzaldehyde, anisaldehyde, 2-hydroxy-5-methyl benzaldehyde, 2-hydroxy-m-tolylaldehyde, 6-hydroxy-m-tolylaldehyde, 2-hydroxy-5-bromo-benzaldehyde, 2-hydroxy-3-nitro benzaldehyde, 2,4-dihydroxy-benzaldehyde, vanillin, piperonal, and 2-hydroxy-naphthaldehyde-1, have been prepared and examined for phototropy. A list of these is given in reference No. 114.

*Hydrazones and osazones.* A number of phototropic hydrazones derived from aromatic hydrazines are known, as are also certain osazones derived from aromatic alpha diketones. The general structure of the hydrazones may be exemplified by benzaldehyde phenylhydrazone:

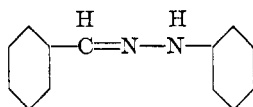

Benzil phenyl osazone shows the typical osazone structure:

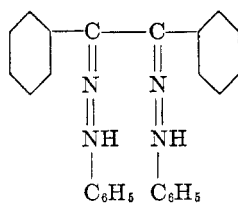

In table 4 are listed all the known phototropic hydrazones and osazones. As with the anils, the data given refer to the hydrazone or osazone formed by the condensation of the hydrazine named over the datum with the aldehyde, ester, or  $\alpha$ -diketone named at the side. In listing the hydrazines only the

TABLE 4  
The phototropic hydrazones and osazones

	HYDRAZINES																						
	Phenyl	o-Tolyl	m-Tolyl	p-Tolyl	o-Chlorophenyl	m-Chlorophenyl	p-Chlorophenyl	p-Bromophenyl	Anisyl	Xyl <sup>1</sup> , 1, 2, 4 (NHNH <sub>2</sub> :CH <sub>3</sub> :CH <sub>3</sub> :1:2:4)	Xyl <sup>1</sup> , 1, 2, 5	Xyl <sup>1</sup> , 1, 3, 4	Xyl <sup>1</sup> , 1, 3, 5	$\alpha$ -Naphthyl	$\beta$ -Naphthyl	Methylphenyl	Diphenyl	Phenylbenzyl	Di-p-tolyl	Phenyl- $\beta$ -naphthyl			
Benzaldehyde.....	(6)								++						++								
Cinnamic aldehyde.....	(70)								++						++								
o-Tolyl-aldehyde.....		+							++						++								
m-Tolyl-aldehyde.....		+	+						++						++								
p-Tolyl-aldehyde.....	(70)			+					++						++								
Cuminal.....									++						++								
Salicyl-aldehyde.....									++						++								
m-Hydroxybenzaldehyde.....									++						++								
p-Hydroxybenzaldehyde.....									++						++								
o-Methoxybenzaldehyde.....									++						++								
m-Methoxybenzaldehyde.....									++						++								
Anisaldehyde.....	(63)								++						++								
2, 4-Dihydroxybenzaldehyde.....									++						++								
Vanillin.....									++						++								
Veratryl-aldehyde.....									++						++								
o-Aminobenzaldehyde.....									++						++								
p-Dimethylamino-benzaldehyde.....									++						++								
Piperonal.....	(70)								++						++								
Furfural.....	(88)								++						++								
9-Ketofluorene-4-carbonic acid ester.....	(118)								++						++								
Dimethylolacetic acid diethyl ester.....	(111)								++						++								

OSAZONES													
	(7)	(74, 75)	(75)	(74, 75)					(66)	(66)	(74)	(76)	(76)
Benzil.....	+	+ $\beta$	+ $\beta$	+ $\beta$							+ $\beta$ (74)	-	-
Curminil.....	+ $\beta$	- $\beta$	+ $\beta$	+ $\beta$					+		+ $\beta$ (75)	-	-
Anisil.....	+	+	+	+ $\beta$					+		+ $\beta$ (74)	-	-
Piperil.....	+	+	+	+ $\beta$					+		+ $\beta$ (74)	-	-

distinctive part of the name of the hydrazine is given. Thus, "phenyl" represents phenylhydrazine; "o-Tolyl" represents o-Tolylhydrazine; "Diphenyl" stands for Diphenylhydrazine, and so on. In the case of each aldehyde, ester, and diketone named in this table every hydrazine derivative which has been specifically studied for phototropy is listed whether it is phototropic or not.

The osazones occur in stereoisomeric forms. Both forms of the phenyl osazones of benzil, anisil, and piperil have been studied for phototropy, and found to be phototropic. Only one modification of the other osazones has been studied. When the classification of this modification has been noted in the literature this is indicated by the letter  $\beta$ , since all listed osazones that have been identified, with the exception of the three forms just referred to, are designated as  $\beta$ .

The positive and negative signs and blank spaces have the same significance as in table 3.

In addition to the compounds listed in table 4 the following hydrazones and osazones have been examined for phototropy and found not to be phototropic:

The  $\beta$ -naphthylhydrazones of acetaldehyde, phenyl-acetaldehyde, propionaldehyde, n-butylaldehyde, iso-valerylaldehyde, galactose, glucose, acetone, o-nitrobenzaldehyde, m-nitrobenzaldehyde, and p-nitrobenzaldehyde (118)

The phenylhydrazone, p-tolylhydrazone,  $\beta$ -naphthyl-hydrazone, and diphenylhydrazone of acetaphenone (10)

The  $\alpha$  and  $\beta$  forms of salicyl-phenylosazone (7)

Of the two hundred odd hydrazones and osazones which have been investigated 57 hydrazones and 20 osazones (not counting the stereoisomers as individuals) have been found to be phototropic.

*Fulgides.* Stobbe has investigated a whole series of compounds some of which he discovered to be phototropic (109), and of which the parent substances are called "fulgides" and are considered to be derived from the acid anhydride,

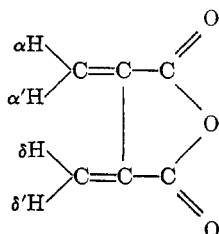

by substitution of the lettered hydrogen atoms.

Corresponding to the fulgides proper, i.e., the substituted acid anhydrides, there can also be prepared the free acids, derived from,

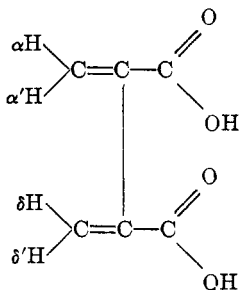

and also salts and esters of the acids.

Belonging to this series there are, then, the fulgides, the fulgic acids, the salts of the acids and the esters of the acids. As there are in the parent substance four hydrogen atoms which may be substituted by organic radicals, and as all fulgides may exhibit cis-trans isomerism it will be seen that the possible derivatives of the parent substance are innumerable. Consider for a moment the fulgide series which may be obtained by the use of only the phenyl group as substituent. There could be one monophenylfulgide, two diphenyl fulgides, one triphenyl and one tetraphenyl fulgide, making four in all, not counting the stereoisomers. From each fulgide a fulgic acid may be obtained, and from each fulgic acid a series of salts and esters, and mixed esters and salts. Moreover, even the neutral sodium salt of a given fulgic acid may or may not be phototropic depending on whether or not the salt is anhydrous or contains water of crystallization.

TABLE 5

<i>The phototropic fulgides</i>	
$\alpha$ -phenyl- $\delta$ $\delta'$ -dimethyl fulgide.....	-
Allo- $\alpha$ -phenyl- $\delta$ $\delta'$ -dimethyl fulgide.....	-
$\alpha$ -Phenyl- $\alpha'$ $\delta$ $\delta'$ -trimethyl fulgide.....	-
Allo- $\alpha$ -phenyl- $\alpha'$ $\delta$ $\delta'$ -trimethyl fulgide.....	-
$\alpha$ -(p-Tolyl)- $\delta$ $\delta'$ -dimethyl fulgide.....	-
$\alpha$ -Cumyl- $\delta$ $\delta'$ -dimethyl fulgide.....	-
$\alpha$ -(o-Nitrophenyl)- $\delta$ $\delta'$ -dimethyl fulgide.....	-
$\alpha$ -(m-Nitrophenyl)- $\delta$ $\delta'$ -dimethyl fulgide.....	-
$\alpha$ -(p-Nitrophenyl)- $\delta$ $\delta'$ -dimethyl fulgide.....	-
$\alpha$ -(o-Methoxyphenyl)- $\delta$ $\delta'$ -dimethyl fulgide.....	-
$\alpha$ -Anisyl- $\delta$ $\delta'$ -dimethyl fulgide.....	-
$\alpha$ -Veratryl- $\delta$ $\delta'$ -dimethyl fulgide.....	-
$\alpha$ -Piperonyl- $\delta$ $\delta'$ -dimethyl fulgide.....	+
$\alpha$ - $\delta$ -Diphenyl fulgide.....	+
$\alpha$ - $\delta$ -Diphenyl- $\delta$ $\delta'$ -dimethyl fulgide.....	+
$\alpha$ $\alpha'$ -Diphenyl- $\delta$ $\delta'$ -dimethyl fulgide.....	+
$\alpha$ -Anisyl- $\delta$ -phenyl fulgide.....	+
$\alpha$ -Piperonyl- $\delta$ -phenyl fulgide.....	+
$\alpha$ -Piperonyl- $\delta$ -phenyl- $\delta'$ -methyl fulgide.....	-
$\alpha$ -Piperonyl- $\delta$ -naphthyl- $\delta'$ -methyl fulgide.....	-
$\alpha$ - $\delta$ -Dicumyl fulgide.....	+
$\alpha$ $\delta$ -Dicumyl isofulgide.....	+
$\alpha$ $\delta$ -dianisyl fulgide.....	+
$\alpha$ $\delta$ -diveratryl fulgide.....	+
$\alpha$ $\delta$ -dipiperonyl fulgide.....	-
Allo- $\alpha$ $\delta$ -dipiperonyl fulgide.....	-
$\alpha$ $\delta$ $\delta'$ -triphenyl fulgide.....	+
$\alpha$ -(p-Tolyl)- $\delta$ $\delta'$ -diphenyl fulgide.....	+
$\alpha$ -Cumyl- $\delta$ $\delta'$ -diphenyl fulgide.....	+
$\alpha$ -(p-Chlorophenyl)- $\delta$ $\delta'$ -diphenyl fulgide.....	+
$\alpha$ -(o-Nitrophenyl)- $\delta$ $\delta'$ -diphenyl fulgide + $1\frac{1}{2}$ CHCl <sub>3</sub> .....	+
$\alpha$ -(m-Nitrophenyl)- $\delta$ $\delta'$ -diphenyl fulgide.....	-
$\alpha$ -(p-Nitrophenyl)- $\delta$ $\delta'$ -diphenyl fulgide.....	+
$\alpha$ -(o-Methoxyphenyl)- $\delta$ $\delta'$ -diphenyl fulgide.....	+
$\alpha$ -(p-Methoxyphenyl)- $\delta$ $\delta'$ -diphenyl fulgide.....	+
$\alpha$ -(o-Ethoxyphenyl)- $\delta$ $\delta'$ -diphenylfulgide.....	+
$\alpha$ -Anisyl- $\delta$ $\delta'$ -diphenyl fulgide.....	-
$\alpha$ -Veratryl- $\delta$ $\delta'$ -diphenyl fulgide.....	+
$\alpha$ -Piperonyl- $\delta$ $\delta'$ -diphenyl fulgide.....	-
$\alpha$ -Piperonyl- $\delta$ $\delta'$ -diphenyl-allo-fulgide.....	+
Tetraphenyl fulgide.....	+
Tetraphenyl-allo-fulgide.....	+

TABLE 5—Continued

<i>The phototropic fulgides—Continued</i>	
$\alpha$ -Styryl- $\delta$ $\delta'$ -dimethyl fulgide.....	—
$\alpha$ $\delta$ -Distyryl fulgide.....	+
$\alpha$ -Styryl- $\delta$ $\delta'$ -diphenyl fulgide.....	+
$\alpha$ -Furyl- $\delta$ $\delta'$ -dimethyl fulgide.....	—
$\alpha$ - $\delta$ -Difuryl fulgide.....	+
$\alpha$ -Furyl- $\delta$ $\delta'$ -diphenyl fulgide.....	+
$\alpha$ -Diphenylene- $\delta$ $\delta'$ -dimethyl fulgide.....	—
$\alpha$ -Diphenylene- $\delta$ -phenyl fulgide.....	—
$\alpha$ -Diphenylene- $\delta$ $\delta'$ -diphenyl fulgide.....	—
<i>Fulgic acids, salts and esters</i>	
$\alpha$ -Phenyl- $\delta$ $\delta'$ -dimethyl- <i>allo</i> -fulgic acid.....	—
$\alpha$ -Phenyl- $\alpha'$ $\delta$ $\delta'$ -trimethyl fulgic acid.....	—
$\alpha$ (p-Tolyl)- $\delta$ $\delta'$ -dimethyl fulgic acid.....	—
$\alpha$ -(o-Nitrophenyl)- $\delta$ $\delta'$ -dimethyl fulgic acid.....	—
$\alpha$ -(m-Nitrophenyl)- $\delta$ $\delta'$ -dimethyl fulgic acid.....	—
$\alpha$ -(p-Nitrophenyl) $\delta$ $\delta'$ -dimethyl fulgic acid.....	—
$\alpha$ -(o-Methoxyphenyl)- $\delta$ $\delta'$ -dimethyl fulgic acid.....	—
$\alpha$ -Anisyl $\delta$ $\delta'$ -dimethyl fulgic acid.....	—
$\alpha$ -Veratryl- $\delta$ $\delta'$ -dimethyl fulgic acid.....	—
$\alpha$ -Piperonyl- $\delta$ $\delta'$ -dimethyl fulgic acid.....	—
$\alpha$ $\delta$ -Diphenyl fulgic acid.....	+
Ester.....	—
Sodium salt + 1 H <sub>2</sub> O.....	+
Sodium salt anhydrous.....	—
$\alpha$ $\delta$ -diphenyl- $\delta'$ -methyl fulgic acid.....	—
$\alpha$ $\alpha'$ -Diphenyl- $\delta$ $\delta'$ -dimethyl fulgic acid.....	—
$\alpha$ -Anisyl- $\delta$ -phenyl fulgic acid.....	—
Sodium salt.....	—
Barium salt.....	—
$\alpha$ -Veratryl- $\delta$ -phenyl fulgic acid.....	—
$\alpha$ -Piperonyl- $\delta$ -phenyl fulgic acid barium salt.....	—
$\alpha$ - $\delta$ -Dianisyl fulgic acid sodium salt.....	—
$\alpha$ $\delta$ -Diveratryl fulgic acid.....	+
$\alpha$ $\delta$ -Dipiperonyl fulgic acid.....	—
Potassium salt.....	—
Ester.....	—
$\alpha$ $\delta$ -Dipiperonyl- <i>allo</i> -fulgic acid potassium salt.....	+
$\alpha$ $\alpha'$ - $\delta$ -Triphenyl fulgic acid.....	+
Sodium salt.....	+
Calcium salt.....	+
Barium salt.....	—
Piperidine salt.....	—

TABLE 5—Continued

<i>Fulgic acids, salts and esters—Continued</i>	
$\alpha$ -(p-Tolyl)- $\delta$ $\delta'$ -diphenyl fulgic acid.....	+
Sodium salt.....	+
$\alpha$ -Cumyl- $\delta$ $\delta'$ -diphenyl fulgic acid.....	-
Sodium salt.....	+
Barium salt.....	+
$\alpha$ -(p-Chlorophenyl)- $\delta$ $\delta'$ -diphenyl fulgic acid.....	+
Acid ester sodium salt.....	+
$\alpha$ -(o-Nitrophenyl)- $\delta$ $\delta'$ -diphenyl fulgic acid.....	+
Sodium salt.....	+
$\alpha$ -(p-Nitrophenyl)- $\delta$ $\delta'$ -diphenyl fulgic acid.....	+
Sodium salt.....	+
$\alpha$ -(o-Methoxyphenyl)- $\delta$ $\delta'$ -diphenyl fulgic acid.....	+
Sodium salt.....	+
Methyl ester.....	+
$\alpha$ -(o-Ethoxyphenyl)- $\delta$ $\delta'$ -diphenyl fulgic acid.....	-
$\alpha$ -Anisyl- $\delta$ $\delta'$ -diphenyl fulgic acid.....	+
$\alpha$ -Veratryl- $\delta$ $\delta'$ -diphenyl fulgic acid.....	+
Potassium salt.....	-
Sodium salt.....	+
Barium salt.....	-
$\alpha$ -Piperonyl- $\delta$ $\delta'$ -diphenyl fulgic acid.....	-
Sodium salt.....	-
Barium salt.....	-
$\alpha$ -Piperonyl- $\delta$ $\delta'$ -diphenyl-allo-fulgic acid.....	-

These considerations may suggest the impossibility of preparing, at least at the present, such a simple graphic table for the fulgide series as was used for the anils and hydrazones to show the relationship, or lack of it, between the occurrence of phototropy and chemical constitution. Therefore the fulgides, fulgic acids, salts and esters are merely listed in table 5 as given by Stobbe (111, 113, 114). A positive sign after the name of a substance indicates that it is phototropic; a negative sign that it is not phototropic.

Of the 52 fulgides investigated 28 are phototropic. Of the 55 fulgic acids and their derivatives 23 are phototropic. The fulgides have initially a yellow to a red color, and the effect of light is to darken the color of the phototropic examples. The fulgic acids and their derivatives are pure white, or at most light yellow, and Stobbe suggests that some of these which he lists as not phototropic may show a change of absorption in the ultra-violet.



*Stilbene derivatives* (115). The dyestuff intermediate, 4,4'-diamino-stilbene-2,2'-disulfonic acid,

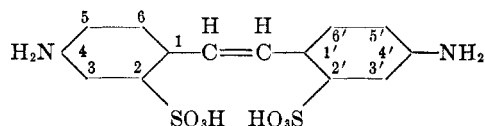

is not itself phototropic, but it is the parent substance of a series of phototropic derivatives. The five known phototropic substances of this series are derived from the original amino stilbene acid by substituting the group  $-\text{COR}$  for one of the hydrogen atoms on each side of the amino groups. These all change from colorless or yellow in the dark to pink in the light and back again in the dark. The known phototropic acids obtained in this way are:

- (1) Diformyl-4,4'-diamino stilbene-2,2'-disulfonic acid;
- (2) Diacetyl-4,4'-diamino stilbene-2,2'-disulfonic acid;
- (3) Diformyl-*p,p'*-diamino-dibenzoyl-4,4'-diaminostilbene-2,2'-disulfonic acid, i.e.,

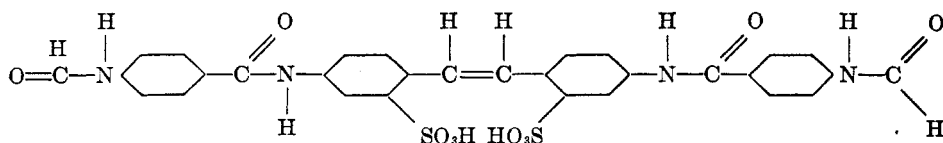

- (4) Diacetyl-*p,p'*-diamino-dibenzoyl-4,4'-diaminostilbene-2,2'-disulfonic acid;
- (5) Diacetyl-*p,p'*-diamino-dibenzoyl-*p,p'*-diamino-dibenzoyl-4,4'-diamino stilbene-2,2'-disulfonic acid, i.e.,

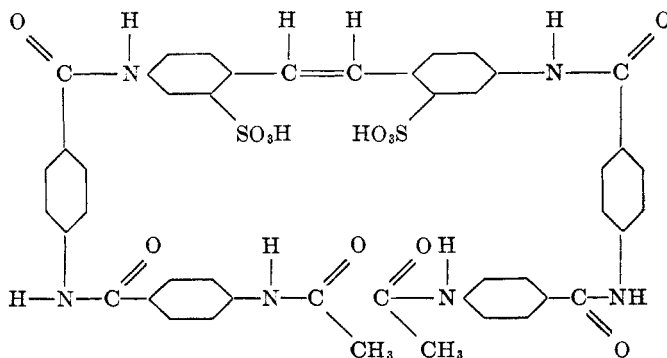

Certain salts of these acids are phototropic as well as the acids themselves. The sodium, potassium, barium, strontium, calcium, magnesium, and lead salts of the diacetyl-diaminostilbene-disulfonic acid are all phototropic.

The following stilbene derivatives have been examined and found to be devoid of phototropic properties: Stilbene; stilbene-2, 2'-disulfonic acid; 4,4'-dinitrostilbene; 4,4'-dinitrostilbene; 4,4'-dinitrostilbene-2,2'-disulfonic acid; 4,4'-dichlorostilbene-2, 2'-disulfonic acid; 4,4'-diaminostilbene; diacetyl-4,4'-diaminostilbene; diformyl-4,4'-diaminostilbene; 4,4'-diaminostilbene-2,2'-disulfonic acid; dibenzoyl-4,4'-diaminostilbene-2,2'-disulfonic acid; di-p-nitrobenzoyl-4,4'-diaminostilbene-2,2'-disulfonic acid; di-p-aminobenzoyl-4,4'-diaminostilbene-2,2'-disulfonic acid; di(p-aminobenzoyl-p-aminobenzoyl)-4,4',-diaminostilbene-2,2'-disulfonic acid.

It should be noted that there exists also a non-phototropic variety of diacetyl-4,4'-diaminostilbene-2,2'-disulfonic acid (19).

*Disulfoxides.* Acetanilide-p-disulfoxide,

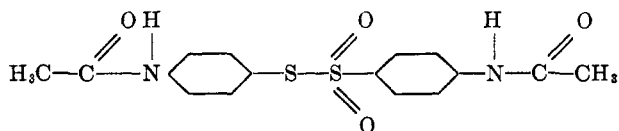

is phototropic (5) when mixed with a small quantity, about 0.1 of 1 per cent acetanilide-p-disulfide (15).

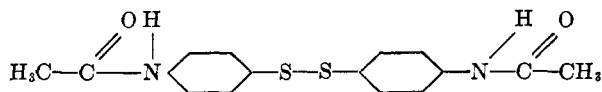

Perfectly pure acetanilide-p-disulfoxide is not phototropic, and neither is its mixture with a greater amount, 5 per cent of the disulfide (15). The disulfide must be in solid solution in the crystals of the disulfoxide in order to confer phototropic properties—simple mechanical mixture is not sufficient—and, as just mentioned, the disulfide must be present in proper concentration. Other phenyl disulfides containing amino groups, or substituted amino groups, para to the sulfur atoms may replace the acetani-

lide disulfide. However, ortho and meta compounds do not exhibit phototropic properties (15).

The following substances, which are probably in reality two component systems like the disulfoxide-disulfide combination just discussed, are also phototropic (15).

- 1-acetylamino-naphthyl-4-disulfoxide
- 2-acetylamino-tolyl-5-disulfoxide
- 4-acetylamino-phenyl-p-chlorobenzenethiosulfonate, i.e.,

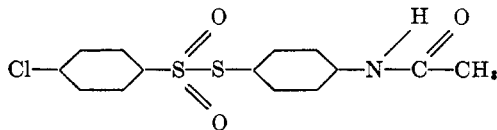

The following related substances are not phototropic:

- Aniline-p-disulfoxide (5)
- Benzanilide-p-disulfoxide (5)
- 3-acetylamino-tolyl-6-disulfoxide (5)
- 1-hydroxy-2-carboxy-phenyl-4 desulfoxide (5)
- Acetanilide-p-disulfone (15)
- p-tolyl-p-acetylamino-benzene thiosulfonate (15)
- p-acetylamino-phenyl-p-acetylamino-benzene sulfonate (15)

A number of corresponding compounds in which the amino groups were ortho or meta to the sulfur atoms were also prepared but were found to be devoid of phototropic properties (15).

With all of the phototropic compounds of this class exposure to light causes the color of the substances to darken. With acetanilide-p-disulfoxide the change is from colorless to yellow. The reverse change takes place in the dark.

*Other solid organic compounds.* In addition to the classes of phototropic organic substances which have been enumerated there are scattered instances of phototropy among other widely differing organic substances.

Anhydrous quinoquinoline hydrochloride,

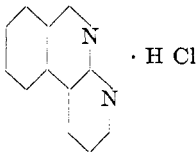

is phototropic (47). This salt turns green in light. A hydrated form of this salt containing 2 molecules of water (48) and various other quinoquinoline salts are known but are not phototropic (47).

$\beta$ -tetrachloro- $\alpha$ -ketonaphthalene is phototropic and turns from colorless to a reddish violet in the light and back again in the dark (47). The substance has the formula,

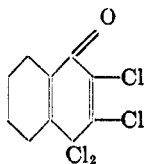

or

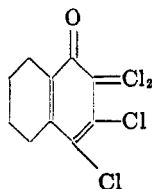

Zincke prepared two different tetrachloro-ketonaphthalenes (133), but only one of these is phototropic (128). If the phototropic variety is melted and then cooled, it is no longer phototropic, but it becomes phototropic again if inoculated with some of the original phototropic material (47, 128).

The potassium salt of dinitroethane is phototropic (13, 30, 117) and changes from yellow to reddish brown in the light and back again in the dark.

Tetraphenyl-dihydrotriazine changes from white to rose in the light, and back again in the dark (126). It apparently has the structure,

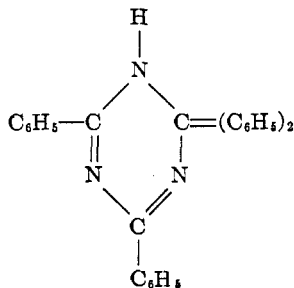

Dimethyl-diphenyl truxone,

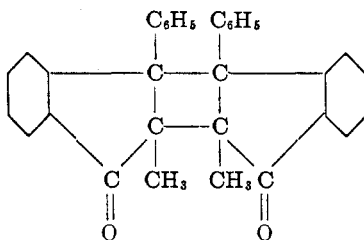

changes from colorless to yellow in sunlight and back again in the dark (16A).

Hexanitro-diphenylamine is phototropic changing bright yellow to brown. It is remarkable for the rapidity of the color changes (114).

$\alpha, \alpha$ -diphenyl- $\alpha, \delta$ -decadiene- $\beta, \gamma$ -dicarboxylic acid anhydride,

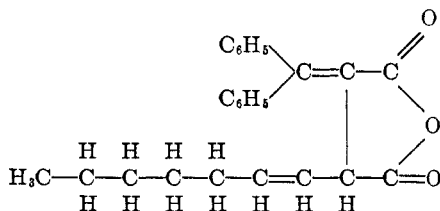

is phototropic, showing a reversible change from yellow green to rose (93). It will be seen that this substance is somewhat similar to the fulgides.

Dibenzylamine-benzil is phototropic (62).

Colorless, solid, alkali containing benzaurine cyanide becomes violet red in sunlight (43).

A film of gelatin stained with methylene blue when exposed (in air) to the light from a Nernst lamp is bleached. If left some days in the dark the blue color returns (39).

*Semicarbazones.* Cinnamic aldehyde semicarbazone is white when freshly prepared, and its color does not change if the compound is stored in the dark or exposed to light. However, if the substance is exposed to sunlight for an hour and then placed in the dark the compound becomes yellow. If the substance

is again exposed to light, the yellow color disappears and the colorless modification so formed will again become yellow if placed in the dark (131). If either the yellow or colorless form is re-crystallized the original colorless form which needs to be exposed to light before it acquires phototropic properties is obtained (131). The relationships may be schematically represented as in figure 1.

In addition to cinnamic aldehyde semicarbazone the semicarbazones of *o*-methoxy-cinnamic aldehyde, of *m*-methoxy-cinnamic aldehyde, and of *p*-methoxy-cinnamic aldehyde, and the phenylsemicarbazones of *o*-methoxy-cinnamic aldehyde and *p*-

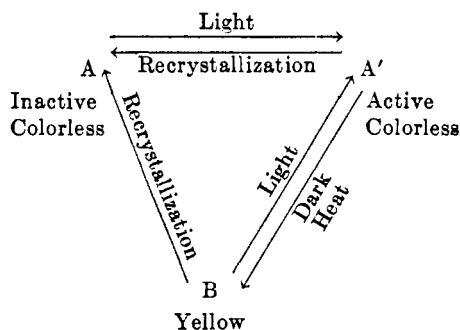

FIG. 1

methoxy-cinnamic aldehyde all exhibit this peculiar behavior to light (33). *O*-methoxy-cinnamic aldehyde thiosemicarbazone and *m*-methoxy-cinnamic aldehyde phenylsemicarbazone do not show these changes (33).

#### *Inorganic substances*

Cuprous chloride and cuprous bromide when under water containing sulfur dioxide, darken in the sunlight and regain their original colorless state when placed in the dark (107).

Lithium imide is phototropic, changing from colorless to brown (16).

Bismuth oxalate is probably phototropic (88A).

Certain samples of strontium platinocyanide show a reversible color change when stimulated by x-rays (38).

*Mercury compounds.* In the last ten years a number of phototropic complex mercuric salts have been reported by Indian chemists. The substances of this class which have been described as phototropic are:—

1. Diiodide-dimercuric-disulfide, I-Hg-S-S-Hg-I (85)
2.  $\text{HgI}_2 \cdot 2\text{HgS}$  (17, 121)
3.  $\text{HgBr}_2 \cdot 2\text{HgS}$  (17, 121)
4.  $\text{ClHgSCN}$  (84)
5.  $\text{BrHgSCN}$  (84)
6.  $\text{IHgSCN}$  (84, 123)
7.  $\text{ClHgBr}$  (84)
8.  $\text{ClHgI}$  (84)
9.  $\text{BrHgI}$  (84)
10. A compound to which is ascribed the formula  $\text{HSHgSCN}$  (122, 123)

The dark stable forms of these substances vary in color from pale yellow to red. In the light they turn brown or black, and revert to their original color in the dark or on warming. The magnitude of the color change varies greatly with the different substances. Nos. 2, 6, and 10 probably show the greatest change in color, and as they become black in the sunlight their color change is more pronounced than with any organic compound.

The mixture of mercurous and silver iodides produced by toning photographic images of silver with mercuric iodide is phototropic (23). The images darken on exposure to light and regain their original reddish color on storage in the dark.

*Alkaline earth sulfides.* Mourelo has for many years investigated a series of phototropic alkaline earth sulfides (51, 52, 53, 54, 55, 56, 57, 58, 59). He has come to the conclusion that the pure alkaline earth sulfides are not phototropic, but that the phototropic substances are solid solutions of traces of activating elements, such as manganese and zinc, in the alkaline earth sulfides (55, 56). His published experiments, however, do not seem to establish this point beyond question.

An example of this type of phototropic substance may be prepared by the addition of 0.05 gram of sodium chloride, 0.15

gram of sodium carbonate, 0.001 gram of manganese in the form of a soluble salt, and excess of flowers of sulfur to 100 grams of strontium carbonate precipitated from strontium nitrate with sodium carbonate. The mixture is placed in a clay crucible and heated to bright redness for 4 hours. The product is greyish and becomes greenish on exposure to light (56).

The close similarity between the composition and methods of preparation of these substances, and phosphorescent sulfides and their preparation is apparent. However the phototropic properties do not appear to be due to the reemission of absorbed light, since some of the phototropic specimens, for instance the one described above, are not phosphorescent, while some of the phosphorescent products are listed as not phototropic. Moreover these compounds become darker colored in light instead of brighter.

The calcium sulfide series (55) and the strontium sulfide series (56) have been rather fully investigated.

*Zinc sulfide.* The malady which afflicted Mr. Griffiths's gate post has dogged the steps of the lithopone manufacturers, and, relating as it does to a commonly used substance, has been the subject of much investigation and speculation (11, 12, 18, 32, 41, 45, 46, 60, 61, 82, 89, 90, 130). Not only is lithopone itself phototropic, but pure zinc sulfide is phototropic, and the phototropic properties of lithopone are dependent upon the presence of the zinc sulfide (11, 12, 41, 60).

Hydrated, i.e., unignited zinc sulfide is not ordinarily light sensitive. If, however, the unignited zinc sulfide is boiled with a solution containing zinc ions it becomes phototropic, and retains its phototropic properties even after it has been washed as free as possible from soluble zinc salts (60, 130).

Ordinarily, however, zinc sulfide becomes phototropic only after having been heated. This effect of heating seems to be dependent upon the conversion of the zinc sulfide crystals, which are originally in the form of zinc blende, into the Wurtzite modification (89). The ignited zinc sulfide is photosensitive only when moist, and its sensitiveness is greatly increased if it is moistened with a zinc sulfate solution instead of pure water



(12). Ammonia, and formaldehyde also increase the sensitiveness (41). Lithopone suspended in celluloid is very sensitive (18).

It is only natural that the phototropy of ignited zinc sulfide should have been observed in the investigation of phosphorescent materials independently of the observations upon lithopone. Hauser (32) seems to have been the first to note the phototropy of specimens of phosphorescent zinc sulfide, although lithopone itself is also phosphorescent (11). Lenard (41) has investigated at some length the phototropic behavior of certain zinc sulfide phosphors. His results are quite consistent with those obtained by the lithopone investigators. There seems to be no direct connection between the phototropy and phosphorescence of zinc sulfide (41, 90).

Zinc oxide is not phototropic (41).

#### *The color change*

The general nature of the color changes exhibited by the various classes of phototropic substances has already been mentioned in enumerating the phototropic compounds. In many cases the mere fact that a substance changes, from, say, yellow to red, is all that is known about its color change.

In  $\beta$ -tetrachloro- $\alpha$ -ketonaphthalene (47), the fulgides (109, 111), the hydrazones and osazones (67), and the anils, the phototropic change manifests itself in an increased pleochroism of the crystals. When individual crystals of these phototropic substances are examined it is observed that the color produced by light is much more pronounced when the crystal is looked through in one direction than when it is viewed from other directions. However, some color change is observable from all sides of the crystal (128).

The color change is not uniform throughout the crystal but takes place only where the light has acted (41, 111).

Neither the fulgides (111), the anils (103), nor  $\beta$ -tetrachloro- $\alpha$ -ketonaphthalene (128) show any distortion of their crystalline form when exposed to the light, i.e., the color change is not accompanied by a distortion of the crystal.

If a phototropic compound which has been colored by exposure

to light is dissolved, the color immediately vanishes and the solution obtained appears to be identical with that prepared from the original compound which had not been exposed to light, and the solutions are not phototropic (14, 47, 101, 111).

When  $\beta$ -tetrachloro- $\alpha$ -ketonaphthalene is exposed to light it develops a new absorption band in the green. This change is not due to the shift of an ultraviolet absorption band into the visible spectrum (128).

Padoa and his collaborators made careful investigations of the velocity with which the color changes occurred in certain compounds. Their method was to prepare color standards for comparison by mixing known quantities of the weakly colored and strongly colored varieties of a phototropic substance. These standards contain a known "amount of color." The substance to be investigated is then exposed to light and the formation of color followed by comparison with these standards. The dark reaction was followed in the same way. The reaction rates obtained were found to agree to give constant velocity constants for a first or second order reaction, depending on the substance and whether the reaction was incited by light, or was the dark reaction. In some cases the light reaction is of the second order and the dark reaction of first order; in other cases the reverse is true. With salicylidene- $\beta$ -naphthylamine and benzaldehyde phenylhydrazine the reaction which took place in the light was found to be monomolecular, and that which took place in the dark, bimolecular (73).

Diacetyl-4, 4'-diaminostilbene-2, 2'-disulfonic acid colors in light at the rate corresponding to a bimolecular reaction, and in the dark the reaction is monomolecular. The velocity constants vary with the intensity of the light, but neither variation in the intensity of the light nor in the wave length of the light has any influence upon the order of the reaction with the anil, the hydrazone or the stilbene compound (79).

*The exciting light.* In general it is known that the light which causes the phototropic change is of relatively short wave length, and lies in the blue, violet and ultraviolet regions. In one case, strontium platinocyanide, x-rays are active (38). However,

x-rays have no effect upon the organic phototropic compounds (14, 47).

The spectral sensitiveness of zinc sulfide (11, 41),  $\beta$ -tetrachloro- $\alpha$ -ketonaphthalene (111, 128), the fulgides (111), cinnamic aldehyde semicarbazone (33), and certain hydrazones, osazones, anils, and stilbene derivatives (79, 80, 111, 114, 115), has been investigated.

Solutions of  $\beta$ -tetrachloro- $\alpha$ -ketonaphthalene show the same absorption bands as the solid material which has not been excited by light (128). The absorption spectra of solutions of the fulgides (113) and of cinnamic aldehyde semicarbazone (33), have also been investigated.

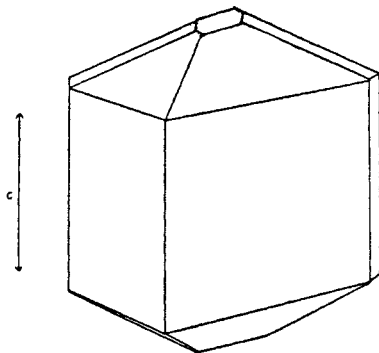

FIG. 2

The magnitude of the color change produced in  $\beta$ -tetrachloro- $\alpha$ -ketonaphthalene depends not only on the intensity of the light but also on the direction from which the light shines upon the crystal (128). This is due to the fact that light of wave lengths which are absorbed by the phototropically induced absorption band has the effect of causing this absorption band to disappear (111); and that the crystals are pleochroic.

The relationships may be made clearer by the reference to figure 2. This shows the crystal of  $\beta$ -tetrachloro- $\alpha$ -ketonaphthalene as described by Weigert, the crystal axes being  $a:b:c :: 0.725:1:0.504$  (128). The phototropic color change is most pronounced along the axis which lies parallel to the edges of the prism faces, i.e.,

in the direction indicated by the double pointed line, "c". Light shining from any direction may excite the phototropic change, but since the reversing light is absorbed primarily when shining in the "c" direction, polychromatic light is most effective in exciting the phototropic color change when it shines in the a-b plane, and not along the c axis. Weigert carried out this investigation with plane polarized light. The original should be consulted for details (128). These relationships have so far been developed only for  $\beta$ -tetrachloro- $\alpha$ -ketonaphthalene.

*The reversing light.* As has just been mentioned, light absorbed by the light induced absorption band of  $\beta$ -tetrachloro- $\alpha$ -ketonaphthalene has the tendency to reverse the action of the exciting light, that is, to cause the absorption band to disappear. This antagonistic action of light of different wave lengths acting upon phototropic substances was discovered by Stobbe in working with the fulgides (111, 112), and it has since been observed that the phenomenon is of wide occurrence among phototropic compounds, and is also observed with other photosensitive systems (104).

With all of the phototropic substances which have been examined in regard to the antagonistic effect of different radiations it has been found that the reversing light is the same or of longer wave length than the light which originally excited the phototropic change. The two effects ordinarily overlap, and light of a given wave length can serve both to excite the phototropic change and to repress it. However, in general it seems that the maximum reversing effect is shown by light of longer wave length than the light which exerts the maximum exciting effect (11, 112, 114, 115). Only a study of individual crystals such as carried out by Weigert could be expected to give accurate data on this question.

The speed with which the fading of the phototropically induced absorption band proceeds under the influence of the reversing light varies greatly with different substances.

In some cases the reversing action is very vigorous. Salicylidene aniline, for instance, hardly shows any color change in sunlight, yet if the sunlight is passed through a blue filter before shin-

ing upon the anil a strong color change, from light yellow to reddish brown, is observed. Here the substance is so sensitive to the reversing action of the long wave length rays that white light will actually cause a sample that has been darkened under a blue filter to fade.

Light is reported to have a reversing action upon the following classes of phototropic substances: The fulgides (11, 113), the stilbene derivatives (114), the anils (79, 80, 115), the complex mercury sulfides (121), and,  $\beta$ -tetrachloro- $\alpha$ -ketonaphthalene, as mentioned above. Whether or not the hydrazones and osazonones show the effect is in question (11, 115).

Some quantitative studies of the reversing action of light upon some of these substances, have been made (79, 80, 115, 128).

*Temperature effects.* Variation in the temperature influences the phototropic process in two distinct ways: (1) it causes a change in the light absorption which induces the phototropic change; and (2) it influences the rates at which the light induced coloration and the reverse change proceed.

The wave length of the light which is effective in bringing about the phototropic change is not a constant that depends only on the nature of the phototropic substance, but depends both on the nature of the substance and the temperature of the substance. The variation in color of a substance with the temperature, or "thermotropy" as Senier has termed it, (102), is a phenomenon of wide occurrence, and is by no means limited to phototropic substances. However, certain of the phototropic substances, not only organic but inorganic (59), and other members of the same chemical groups, exhibit thermotropy to a marked degree (95, 96, 97, 98, 99, 100, 101, 102, 103, 111). The sense of the change, at least as far as phototropic solids are concerned, is such that an increase in temperature causes absorption bands to shift so as to take up light of longer wave lengths, and decrease in temperature causes the absorption bands to shift in the opposite direction. Therefore at temperatures of  $-100$  to  $-200^{\circ}$  it frequently happens that phototropic substances can be excited only by light of much shorter wave length than is required at ordinary temperatures. For instance,  $\alpha$ -anisyl- $\delta,\delta'$ -diphenyl-

fulgide when its temperature is above 22 degrees is completely excited by light of wave length longer than 2970 A., while below  $-35^{\circ}$  it is, under the same conditions of illumination, not excited by light of wave length longer than this figure (111). Stobbe has collected similar information relative to a number of other fulgides, hydrazones, and stilbene derivatives. He makes the general statement that all phototropic substances are thermotropic (115).

Padoa and his collaborators have devoted much attention to the influence of temperature on the rates with which phototropic substances change their color. Their methods of working have been to prepare for each phototropic substance, two different color standards which corresponded to the colors exhibited by the substance in different stages of excitation. The time required for the color of a substance to change from that of one of these standards to that of the other standard was determined for different temperatures. From these values, temperature coefficients were deduced. The figure given as the temperature coefficient represents the time required for the definite color change just described divided by the time required for the same color change after the temperature of the substance had been raised  $10^{\circ}$ . In determining the temperature coefficients for the light reaction, a constant light intensity was used at the different temperatures.

For determining the temperature coefficient of the light reaction it will be seen that there is a theoretical objection to this method as here outlined. While the phototropic substance is being excited by light, the dark reaction is going on, and the effect of this is to retard the light reaction. Moreover, a decrease in temperature slows up the dark reaction much more than it does the light reaction, and therefore the retarding influence of the dark reaction is relatively decreased. The temperature coefficient of the light reaction would therefore tend to appear smaller than it actually is. Practically, this objection is of little importance in view of the fact that the absolute speed of the light reaction is usually very much greater even at ordinary temperatures than the speed of the dark reaction.

As just mentioned, the influence of temperature upon the dark reaction is much greater than upon the light reaction. This seems to be very generally true of phototropic solids.

The temperature coefficients obtained by this method are listed in table 6.

Except for triphenyl fulgide the data given in table 6 for the temperature coefficients of the reactions which take place in the light all refer to the use of white light. If colored lights are used the temperature coefficient is found to vary with the color of the light (79, 80), as was predicted by Trautz (119). For salicylidene- $\beta$ -naphthylamine the temperature coefficient for green light is 1.80, for blue light is 1.45, and for violet light, 1.39 (79). For benzaldehyde phenylhydrazone the temperature coefficient

TABLE 6  
*Temperature coefficients of phototropic reactions*

SUBSTANCE	REACTION IN DARK	REACTION IN LIGHT	REFERENCE
Benzaldehyde phenylhydrazone.....	1.7	1.07	(67, 73, 78)
Piperil-o-tolylosazone.....	2.0	1.06	(78)
Benzil-o-tolylosazone.....		1.05	(80)
Salicylidene- $\beta$ -naphthylamine.....	2.0	1.47	(67)
Triphenylfulgide.....	(blue light)	1.29	(80)
Diacetyl-diaminostilbene-disulfonic acid.	1.65	1.07	(79)

for blue light is 1.08, and for violet light is 1.04 (80). Triphenylfulgide has a temperature coefficient of 1.67 when excited by green light (80).

The decolorizing reaction produced by the reversing light is also influenced by temperature. In the decolorization of triphenylfulgide by yellow light (6140-5740 A.) the temperature coefficient is 0.89, and for red light is 1.08 (80). There should be some wave length in between at which the reaction would be independent of the temperature. This remarkable case of a temperature coefficient of less than one has a parallel in a system described by Skrabal (108).

Another way of dealing with the effect of temperature is to consider the increase in intensity of light required to hold a pho-

totropic substance to a given color when the temperature is raised. This study has been made in some cases (67, 111). The light intensity required increases rapidly with the temperature. For instance, salicylidene- $\beta$ -naphthylamine requires an increase in light intensity of 1.4 for each increase of  $10^\circ$  in temperature. Salicylidene-aniline requires the light intensity to be increased 1.7 for each  $10^\circ$  (67). These results agree with calculations based on the temperature coefficients.

Since the speed of the dark reaction increases with the temperature much more rapidly than the speed of the light reaction it will be seen that as the temperature rises a point must be reached at which the dark reaction becomes so rapid that phototropy can no longer occur, or, in other words, we reach a point at which the energy required to maintain even the slightest color change in a phototropic substance becomes enormously great. Just how accurately this "higher temperature limit," as Senier named it (103), can be determined is not known, but Senier has arrived at it within a few degrees for the phototropic anils which he has studied. One would expect the critical temperature to be a region rather than a point, something like the threshold value of a photographic plate as determined for speed measurements.

In order to show the range of these critical excitation temperatures the values which have been determined for the phototropic anils are listed in table 7. Similar data on certain fulgides, hydrazones, osazones, and stilbene derivatives are given by Stobbe (111, 114, 115), and there are other values scattered through the literature. Since these critical temperatures have not been correlated with the other properties of phototropic substances, their significance is somewhat doubtful.

It will be observed that two of the anils are phototropic only at temperatures below room temperature. One remains phototropic at temperatures above  $100^\circ$ .

In contrast to the behavior of these organic substances the rate of darkening of zinc sulfide does not seem to be greatly affected by temperature (11).

*Photoelectric effect.* Amaduzzi and Padoa (1) and Gallagher (25) have studied the photoelectric effect with phototropic sub-



stances. The original papers must be consulted for details since the results are not altogether concordant and do not permit of being condensed into generalizations.

Amaduzzi and Padoa concluded that in general, though not always, phototropic substances have more photoelectric power than substances of similar constitution which are not phototropic. From Gallagher's curves, it would seem that photoelectric fatigue is less pronounced with phototropic substances, i.e., phototropic compounds when exposed to light continue to emit steady streams of electrons longer than do similar compounds which are not phototropic.

TABLE 7  
*Temperature limits of phototropy in anils (103)*

ANIL	HIGHER TEMPERATURE LIMIT
	°C.
Salicylidene aniline.....	50.5*
Salicylidene-m-toluidine.....	39.5*
Salicylidene-1,3,4,-xylylidine.....	76*
Salicylidene-o-chloroaniline.....	82-83*
Disalicylidene-m-phenylenediamine (needles).....	75
Disalicylidene-m-phenylenediamine (plates).....	30
Salicylidene-o-bromoaniline.....	65
Salicylidene-p-bromoaniline.....	48
Salicylidene-o-anisidine.....	30
Salicylidene-p-aminobenzoic acid.....	20 (about)
Salicylidene-p-anisidine.....	Between 20 and -20
2-hydroxy-3-methoxybenzylidene-1,2,5-xylylidine.....	Between 0 and -20
Salicylidene- $\beta$ -naphthylamine.....	Between 110 and 126

\* Melting point.

Kowalski found that strontium platinocyanide which had been changed by x-rays into the phototropically excited form showed the photoelectric effect much more strongly than strontium platinocyanide which had not been exposed to x-rays (38).

If a plate covered with lithopone which has been darkened by exposure to light is connected to an electroscope and exposed to light of different wave lengths, the rate of leak of the electroscope is found to agree within a few per cent with the rate of leak when the lithopone plate is replaced by a plate of metallic zinc (11).

*Mixed crystals.* Padoa found that mixed crystals could be formed of benzaldehyde phenylhydrazone and a small proportion of benzylidene-benzylamine, and of benzaldehyde phenylhydrazone and a small proportion of diazoaminobenzene. Benzaldehyde phenylhydrazone crystals containing only very small amounts of benzylidene-benzylamine are still very phototropic. But when the anil content is increased to 5 per cent, the phototropy completely vanishes. When the content of the anil is sufficient to affect the phototropic properties, but not to extinguish the light change, the effect of the adulterant is to make the color change less pronounced and to cause the dark change to take place more rapidly than with pure benzaldehyde phenylhydrazone (63).

*Amorphous mixtures.* Dr. Scheiber working with Stobbe (114) prepared a number of mixtures of phototropic substances with various resins. Representative stilbene derivatives, osazones, hydrazones, anils, and fulgides were investigated. In some cases, the resinous mixtures were phototropic, in others no phototropic properties were shown. Frequently a mixture of a given resin and a given phototropic substance would be phototropic or not, depending on whether the mixture was prepared by warming the constituents together, or by precipitating them from solution. In some cases, such as that of benzaldehyde phenylhydrazone in metastyrol an inversion of the phototropic color change occurred, and the effect of light was to cause the color of the dark stable modification to fade.  $\beta$ -tetrachloro- $\alpha$ -ketonaphthalene was mixed with a number of colloidal materials. Some of the mixtures were phototropic and some were not. In some of the mixtures in which phototropy was observed there was clearly some crystallization of the phototropic substance. Stobbe believes that the behavior of  $\beta$ -tetrachloro- $\alpha$ -ketonaphthalene is such as to differentiate it from the other substances examined. In view of the inconsistencies in the behavior of the other phototropic materials when mixed with colloids this conclusion does not seem altogether beyond question.

Stobbe has also been able to stain wool, cotton and silk with fulgides and anils (113, 114). These stained fabrics are photo-

tropic, though their reaction to light is less strong than that of the original substances.

*Energy relationships.* While no exhaustive investigations of the point appear to have been made it is generally agreed that phototropy is a completely reversible phenomenon. The dark reaction proceeds spontaneously, and therefore, if the phenomenon is truly reversible, it must be considered that the colored modification in the typical equation,

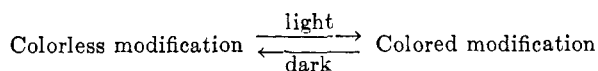

is the colorless modification which has absorbed a certain amount of energy. Moreover, this energy must be liberated again in the dark reaction.

TABLE 8  
*Heats of combustion of phototropic modifications*

SUBSTANCE	HEAT OF COMBUSTION		DIFFER- ENCE	REFERENCE
	Unexcited	Excited		
	<i>cal./gram</i>	<i>cal./gram</i>	<i>cal./gram</i>	
Triphenyl-fulgide.....	7810.4	7816.9	6.5	(114)
Salicylidene- $\beta$ -naphthylamine.....	8291.5	8294.4	2.9	(68)
Benzaldehyde-phenylhydrazone.....	8668.8	8669.1	0.3	(68)

This line of reasoning leads directly to two questions: (1) How much more energy is possessed by the colored modification than the colorless modification? (2) In what form is the energy liberated during the dark reaction? Attempts have been made to answer both questions.

In order to determine the energy differences between the dark stable and light excited modifications of phototropic substances the heats of combustion of three substances in the two different states were measured. The results are given in table 8.

The differences are all in the expected direction, but they are so small, none being as much as 0.1 of 1 per cent of the total heat of combustion that it is doubtful if they are larger than the experimental error of the determinations. The safest conclusion

to draw is merely that the energy difference between the excited and unexcited states is very small.

From the standpoint of a reversible reaction a purely formal consideration of phototropy might lead one to expect that the energy liberated in the dark reaction would be given off in the form of light, i.e., the substances would be phosphorescent. Gallagher believed that he had observed the liberation of some form of radiant energy in the cases of disalicylidene-*m*-phenylenediamine and benzaldehyde phenylhydrazone (25). He described in particular the work with benzaldehyde phenylhydrazone. His evidence, which was both visual and photographic, will be discussed.

Gallagher reported three experiments made upon the action of the excited form of benzaldehyde phenylhydrazone upon photographic plates. In the first experiment the phototropic sample was placed upon a photographic plate, the whole heated to 50° for 20 minutes and the plate developed. Those portions of the plate around where the substance had been placed were found to be blackened. The second experiment was carried out like the first except that a piece of metal foil was placed below the substance. "Cette fois, il-y-avait une image en noir de la feuille de clinquant sur la plaque et, comme dans la première expérience, les autres parties de la plaque qui, n'étaient pas en contact avec la substance étaient noircies." In the third experiment the photographic plate was wrapped in black paper. A piece of lead and the phototropic material were placed on top of the paper. In this case the whole plate was blackened, but in the center there appeared an image, blacker than the rest of the plate, of the piece of lead.

Working along the same lines Venkataramaiah and Janakiram made experiments with  $\text{HgI}_2 \cdot 2\text{HgS}$ ,  $\text{IHgCNS}$ , and the compound described as  $\text{HSHgCNS}$ .

The substances were taken in small capsules or phials open at one end. The mouths of these were closed with microscopic slides, numbering 1, 2, 4, 6, and 8, using sealing wax to keep them in contact with the capsules. After the compounds were excited in strong sunlight, the capsules were placed over a photographic plate and left in the dark for about two days when the compounds completely recovered. It was

observed that, as the number of slides was increased, the image produced on the plate became more and more faint and when the number exceeded twenty, the image became imperceptible. . . . It is curious to note that in every case it was the positive that was printed on the plate (124).

Presumably the last sentence means that where the plate was actually protected by contact with a cover glass there was no blackening; the blackening took place around the edges of the cover glass.

Such photographic evidence of radiant energy as that obtained by Gallagher and Venkataramaiah and Janakiram is anything but convincing, and has the earmarks of the Russell Effect. Gallagher did not describe his photographic results very clearly, and his plates were not reproduced with his article. However, his results certainly do not preclude chemical fogging of the plates. Benzaldehyde is known to produce the Russell Effect (37), and the benzaldehyde phenylhydrazone itself is readily oxidized by air (116). In his third experiment the black paper very possibly caused fogging. Venkataramaiah and Janakiram's account of their experiments is as clear a description of the Russell Effect, caused by the sealing wax (87, 120), as could be desired.

Stobbe found that during the dark reactions the fulgides (111) produced no image upon a photographic plate. The stilbene derivatives chemically fog a plate but give no evidence of emitting light (115). Cinnamicaldehyde semicarbazone is without action on a photographic plate.

Gallagher's further observation was that if light excited benzaldehyde phenylhydrazone were placed on a watch glass and both heated to 100° the watch glass glowed (25).

Zanella (132) was unable to obtain the fluorescence of the watch glass which Gallagher reported. He also found that the dark stable form of benzaldehyde phenylhydrazone behaved exactly the same toward a photographic plate as the light excited form. The plate was fogged, just as Gallagher found, if only the black paper was interposed between the plate and the phototropic substance. However, if there were interposed between

the photographic emulsion and the phototropic substance a perforated brass plate 0.7 mm. thick, a gypsum plate a few tenths of a mm. thick, and a glass plate a few thousandths of a mm. thick, there was no action upon the photographic plate. Zanella concluded that the action observed by Gallagher upon the photographic plate was due purely to some chemical decomposition of the phototropic substance.

The luminescence of the watch glass observed by Gallagher is difficult to understand. It is not impossible that his watch glass was thermoluminescent.

The energy relationships are of importance to an understanding of the mechanism of phototropy, and it is unfortunate that so little concordant data are available.

*Chemical relationships.* The relations between the constitution of substances and the occurrence of phototropy has already been dealt with in listing the known phototropic compounds. In addition to these observations, certain other parallelisms between phototropic and purely chemical phenomena have been noticed. Many phototropic substances appear to be relatively little affected chemically by long exposure to light. Thus benzaldehyde phenylhydrazone shows only a few degrees lowering in melting point after exposure to daylight for a whole summer, and after exposure it can readily be identified as still benzaldehyde phenylhydrazone (14).

While benzaldehyde phenylhydrazone shows no change in melting point on passing from the colorless to the excited red modification, the melting point of benzaldehyde-o-tolyhydrazone changes from its original value of 100° to 102° to 80° to 83° for the excited form. Benzaldehyde-p-tolyhydrazone also shows a change of melting point of from 114° to 101° (86).

Diphenyl fulgide, is completely decomposed by long exposure to light, and Stobbe reports that it reacts as follows (110, 113):

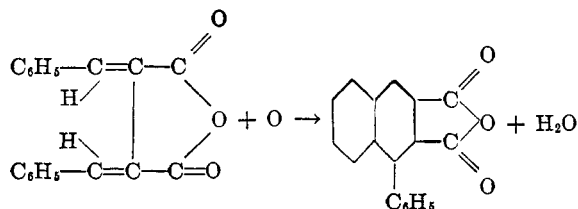

The sodium salt of diacetyl-4,4'-diamino-stilbene-2,2'-disulfonic acid appears to exhibit phototropy only in an atmosphere containing oxygen, and when this substance is exposed to light in an oxygen containing atmosphere, some of the oxygen is converted into ozone (115). The light which effects this reaction is of longer wave length than that required to convert oxygen directly into ozone. It is an interesting case of photo-sensitization. This observation also throws some light on the energy relationships since ozone is an energized form of oxygen.

Hexanitrodiphenylamine also requires an oxygen containing atmosphere in order to exhibit its phototropy (114), but in this case, it is not known whether or not the oxygen suffers any change.

Cinnamicaldehyde semicarbazone too requires oxygen (33).

$\beta$ -tetrachloro- $\alpha$ -ketonaphthalene, and the osazones which have been investigated are phototropic whether they are placed in a vacuum or in an atmosphere of air, or oxygen, or hydrogen, or carbon dioxide (114). With the osazones the presence of oxygen in the surrounding atmosphere seems to have a slight inhibitory action on the color change produced by light.

Various hydrazones, anils, and fulgides are reported to be phototropic in air, oxygen, hydrogen and carbon dioxide, but not in a vacuum (114). The latter is a very curious observation, and is a distinction from the behavior of the osazones and the chloronaphthalene.

The presence or absence of moisture in the surrounding atmosphere seems to have very little effect upon the phototropic properties of any of the substances investigated, i.e., stilbene derivatives, the tetrachloro ketonaphthalene, hydrazones, osazones, anils, fulgides, and hexanitrodiphenylamine (114, 115).

Lithopone will darken when exposed to light only if it is moist. When it has been darkened by the action of light, it requires the presence of oxygen in order to undergo the reverse change in the dark. That is, the substance can be darkened by light in the absence of oxygen, but oxygen or an oxidizing agent is required for the fading which takes place in the dark (12, 41, 60, 83). Lead acetate, ammonia, formaldehyde, and other reducing agents increase the light sensitiveness (11, 41, 60).

When a gelatin film stained with methylene blue is bleached by exposure to light the presence of oxygen is necessary in order that the change may be reversible. In absence of oxygen, the bleaching is more rapid, but the color does not return in the dark (39).

*Fatigue.* On prolonged exposure to light phototropic solids show more or less pronounced fatigue, that is prolonged exposure causes them to undergo the phototropic change less readily or not at all.

The readiness with which phototropic substances fatigue varies greatly with the substances. Benzaldehyde phenylhydrazone (12) and some, at least, of the fulgides (111, 113, 114) fatigue very quickly.  $\text{HgI}_2 \cdot 2\text{HgS}$  (121) and lithopone (82) also show fatigue. In all of these cases the fatigued modification is as light in color, or lighter, than the original dark-stable form. The light first produces the excited colored form of the compound, and then, if the action of light is continued long enough, the color fades until it may be even less pronounced than the color of the original unexcited material. On the other hand, various anils fatigue to darker modifications (96, 97).

Contrasted with these cases of more or less readily produced fatigue, some phototropic substances appear to suffer very little fatigue on exposure to light. Salicylidene aniline, in a sealed Pyrex tube, shows no change in phototropic properties on exposure to daylight for a year.

Profound chemical change may accompany the appearance of fatigue, as in the cases of di- and triphenyl fulgide, mentioned above. On the other hand, a substance may fatigue readily and yet not suffer great chemical change. The latter phenomenon is shown by, for instance, benzaldehyde phenylhydrazone. If a sample of this substance is exposed to light for some time, the red color originally produced by light gradually fades, and the substance, although still exposed to bright light, becomes colorless. However, the melting point does not change greatly, and if the crystals are broken in a mortar, the sample regains its phototropic properties (14).



## PART II. THEORETICAL

*General.* From the resumé of experimental results which has been given, it will be seen that a number of very diverse substances show the phototropic change. In certain cases, definite mechanisms have been developed to account for the color changes exhibited. With the phototropic liquids, whose behaviour has been explained at all, a chemical mechanism is involved. With some of the solid substances, such as lithium imide, and lithopone, we have what appear to be more or less adequate chemical pictures which will account for the phenomena observed. In another case, that of the stilbene derivatives, we have evidence of a chemical change accompanying a phototropic change.

There still remain the classes of phototropic substances which have been most extensively investigated, namely, the fulgides, the anils, the hydrozones, the osazones and  $\beta$ -tetrachloro- $\alpha$ -ketonaphthalene. These substances seem to be more or less closely associated as regards their phototropic properties, and it is on these substances that most thought has been expended in order to develop adequate theories of their behaviour. There is still a lack of agreement among the scientists who have investigated the phenomena of phototropy as to the explanation of the behaviour of these compounds.

In the following summary of theoretical considerations, the various types of reactions which have been proposed for the different instances of phototropy will be discussed independently. Except for the last large class of substances, there is no great disagreement as to the explanation of the behaviour of the compounds. There is often a paucity of material to go on and a certain amount of unfounded conjecture.

*Dye derivatives.* The triphenylmethane dyestuff cyanides, carbinols, and sulfites are assumed by Hantsch to have two forms, but have the one colored and ionizable, and the other colorless and unionized. Hantsch established a parallelism between the loss of color and the loss of ionizing ability when these dye derivatives were first formed and changed into the colorless modifications (31). These ideas have been extended by others, especially as regards the relation of ionization to color (50).

Following this idea of dual forms of the dye derivatives, Lifschitz believes that the colorless form is stable in the dark in solution but that the action of light converts it into the colored form (42). He has followed through, as already described, the relation between the development of color in the light and the development of electrical conductivity in the solutions of these dyestuff derivatives.

We, therefore, have as the mechanism of the phototropic change, the following reactions:

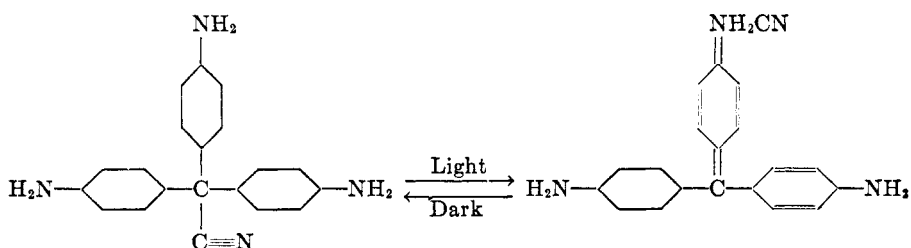

Although this chemical mechanism appears to be adequate, it does not give us a complete picture of the reaction since the energy relationships are left unexplained. The colored, ionized form may be inferred from the work of both Hantsch and Lifschitz to have a higher energy content than the unionized, colorless form. What becomes of this energy when the colored form changes into the colorless is not known.

*Camphor derivatives.* With these substances, Singh has established a parallelism between the color of the solutions and the optical rotation.

Singh believes that we have the following chemical equilibrium which, as indicated, is displaced by light so as to produce the enol form (105, 106):

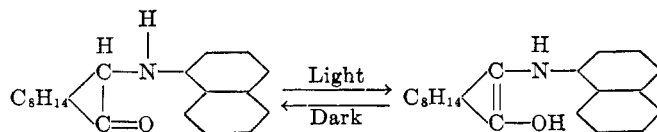

He also finds that the light produced modification has different chemical reactions from the normal stable form, and relies on his

reactions with ferric chloride to substantiate the keto-enol tautomerism of these substances. He believes that the green color of the solutions which have been exposed to light results from a mixture of the keto and enol forms, which may be independently colorless, but which he believes form a colored combination similar to quinhydrone (106).

*Triphenyl methane derivatives.* The solutions of triphenyl methane derivatives, which change their color in light, are supposed to undergo the following reactions (91):

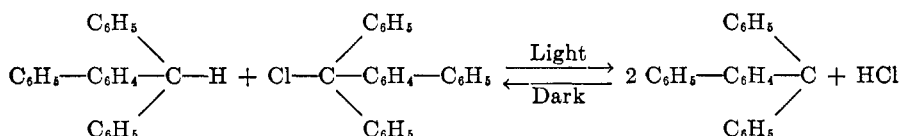

To substantiate this view, it is pointed out that diphenyl-monobiphenyl-methyl and phenyl-dibiphenyl-methyl in benzene solution are relatively sensitive to hydrogen chloride, but are stable to sun-light (91).

*Ferrocyanide solutions.* The coloration produced by light in a solution of potassium ferrocyanide and phenolphthalein is said to be due to the formation of alkali, potassium hydroxide, by light. In the dark the potassium hydroxide is reneutralized and the phenolphthalein loses its red color (4).

*Lithopone.* Phipson originally suggested that lithopone might contain a compound of an unknown photosensitive element for which he proposed the name actinium, but nothing ever came of this suggestion. Cawley suggested that the blackening due to the action of light on lithopone is caused by the formation of metallic zinc in the lithopone (12). He proposed the reactions:

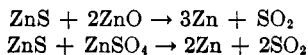

Evidence for Cawley's view that zinc is formed is the fact discovered by Phipson that oxygen was required for the color of lithopone to bleach again in the dark (83). This view has been further extended and generally adopted by others (11, 41, 46, 60). Brickwedde found that lithopone darkened by the pres-

ence of metallic zinc which had been distilled upon its surface, bleached just as fast in the dark as lithopone which had been darkened by exposure to light. As further evidence, he presents the parallelism between the photoelectric effect shown by lithopone darkened by light and a plate of metallic zinc. His theory is that light acts upon the zinc sulfide in lithopone to produce metallic zinc and hydrogen sulfide. As evidence to substantiate this, he points out that lithopone is more sensitive to light when it is moistened with lead acetate solution (11).

However, the actual reaction involved is still a matter of conjecture. Each investigator has had his own opinion, and this had seldom agreed with that of anyone else. Phipson believed in "actinium"; Cawley in the formation of  $\text{SO}_2$ ; Brickwedde in the formation of  $\text{H}_2\text{S}$ ; and Lenard in the formation of zinc and sulfur. Weiser and Garrison say that Lenard's view is absurd, but wisely refrain from committing themselves to any specific chemical reaction.

*Lithium imide.* The mechanism proposed by Dafert and Miklaur (16) is the following:

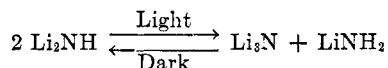

Lithium nitride is known to be brown and is known to react with lithium amide as indicated for the dark reaction.

*Silver and mercurous iodides.* The phototropic mixture of silver iodide and mercurous iodide formed by toning a silver photographic image with mercuric iodide is supposed to undergo the following reactions (23):

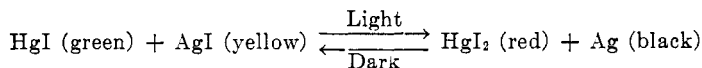

*Stilbene derivatives.* Stobbe assumes that when the phototropic stilbene derivatives are exposed to light they take up oxygen to form a colored organic oxide which may have the structure of an organic peroxide:

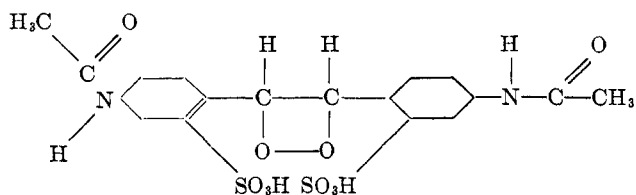

or of an ethylene oxide:

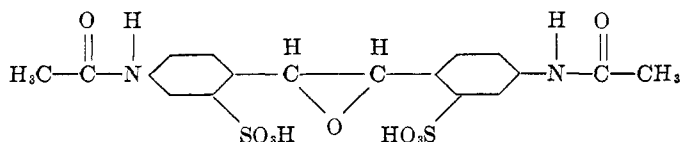

or of an amine oxide:

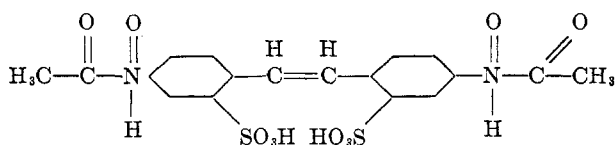

In the dark, the oxide, whatever form it may have, is assumed to revert to the original stilbene compound with the liberation of ozone.

As further support of this theory, Stobbe quotes the findings of Padoa (79), who concluded from the rate of color change of the stilbene derivatives that the reaction produced by light is bimolecular.

The theory has a great advantage over all the other theories that have been proposed in that it accounts for the energy as well as for the possible chemical mechanism. Its weak point lies in the fact that the colored oxides have never been isolated and identified.

*Anils, hydrazones, osazones, fulgides and β-tetrachloro-α-ketonaphthalene*

This most investigated group of phototropic substances has been the subject of much speculation and some critical investigation. While there appears to be no conclusive evidence that

these substances in their phototropic mechanisms form a homogeneous group, most of the investigators have tacitly assumed that these compounds are to be considered together. The reasons for this grouping would appear to be: (a) that these are all pure substances and form pleochroic crystals; (b) the lack of a really satisfactory explanation for the phototropic behavior of any of these substances; and (c) that these are the best known phototropic compounds.

The hypotheses which have been advanced may be divided into those which postulate a purely physical mechanism and those which postulate a purely chemical mechanism.

*Physical theories.* In his original paper on phototropy, Marckwald (47), having observed that only one of the two crystalline modifications, and none of the solutions or melts, of  $\beta$ -tetrachloro- $\alpha$ -ketonaphthalene was phototropic, and that the phototropic change involved an increase in the pleochroism of the crystals, concluded that the phenomenon was bound up with the crystal form, and was purely physical. To give further support to this idea, Weigert (128) pointed out that only one of the two tetrachloro-ketonaphthalenes prepared by Zincke (133) was phototropic, that solutions of the phototropic substance showed the same absorption band as the crystals, but were not phototropic, and that the action of light did not cause a distortion of the phototropic crystals. He again called attention to, and considered in great detail, the pleochroism of the crystals. Stobbe has further shown that the phototropic properties of  $\beta$ -tetrachloro- $\alpha$ -ketonaphthalene remain constant regardless of the nature of the surrounding atmosphere or its pressure (114).

Weigert concluded from his own investigations that the phototrophy of  $\beta$ -tetrachloro- $\alpha$ -ketonaphthalene could be accounted for by his general theory of photochemical action (127). The theory, in its details, cannot be adequately summarized in a brief review, and the original papers (127, 128) should be consulted. Weigert's basic conception is that the absorption of light causes a distortion of the electronic orbits within the phototropic crystal, and that this distortion results in an anomalous absorption of light.

Gallagher synthesized the substance:

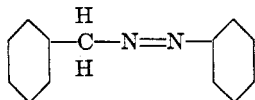

and found that this was stable, both in the dark and in the light (24). From this he concluded that the phototropy of benzaldehyde phenylhydrazone could not be due to the isomeric change:

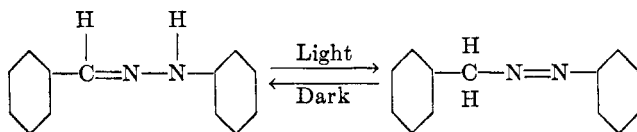

This observation was advanced as further evidence that the phototropic change in benzaldehyde phenylhydrazone is purely physical and not accompanied by a chemical reaction. From his work on the photoelectric effect, Gallagher (25) concluded that the loss of electrons suffered by phototropic substances when they are exposed to light, causes a change in light absorption—just how is not altogether clear.

*Chemical theories.* The chemical theories all assume that the weakly colored phototropic materials which are stable in the dark are converted by light into new chemical substances which are more strongly colored. It is further assumed that in the dark these new chemical compounds change back into the original substances. The theories differ in their assumptions as to just what the new chemical substances formed by light may be. All of the chemical theories suffer from the handicap that no one has been able to isolate or identify, or even conclusively show, the existence of the hypothetical new compounds formed by light. Of course, ultimate photochemical decomposition products have been obtained, but these are not phototropic.

Chattaway (14) believed that benzaldehyde phenylhydrazone was converted by light into a colored isomer, and suggested the equilibrium:

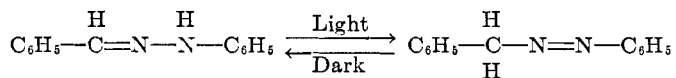

Gallagher's work referred to above was designed to show the fallacy of this particular assumption.

Stobbe also believes in the formation of a colored isomer of some sort in the case of the fulgides (111, 112), and he suggests that the action of light may be to convert a fulgide into a stereoisomeric form and that this form reverts to the original on standing in the dark. He showed that light did convert some fulgides into their stereoisomers: however, the reverse change in the dark does not appear to have been demonstrated, and it would seem that the isomers produced by light are not the colored phototropic forms (113).

Stobbe differentiates between  $\beta$ -tetrachloro- $\alpha$ -ketonaphthalene and the anils, fulgides, hydrazones, osazones and stilbene compounds on the basis of his experiments with amorphous mixtures of the substances, and the behavior of the substances in vacuum (114). He concedes the purely physical nature of the phototropic change in  $\beta$ -tetrachloro- $\alpha$ -ketonaphthalene, and believes that the change in the other classes of compounds is purely chemical. He has considered the formation of a new substance in a photosensitive crystal, and believes that up to a certain relatively high concentration the new substance would form a solid solution in the mother crystal without affecting the crystal structure. Padoa also believes in the possibility of forming such solid solutions, and has experimentally demonstrated the correctness of this view (65).

Senier and Shepherd considered that the phototropic change was an isomerism (101), and more specifically a case of polymerization (102, 103, 104). They assume "the existence of complex solid molecular aggregates related to gaseous molecules as gaseous molecules are related to atoms." (103) A change in aggregation is caused by exposure to light, and this change is reversible. It is further implied that the different aggregates have different colors. Senier and Shepherd believed that the chemical change involved must be very simple because of the ease with which the anils form colored modifications not only under the influence of light but also as a result of the action of heat, crystallization from different solvents, and through other agencies. By crystalliza-



tion from concentrated solutions, they actually prepared a red modification of salicylidene- $\beta$ -naphthylamine, which appeared to be identical with the phototropic form produced by light (103). They consider that their hypothesis offers an adequate mechanism, but they adduce no direct evidence to support it.

Graziani and Bovini observed that the hydrazones derived from diphenyl and ditolyl hydrazines were never phototropic even though the corresponding hydrazones derived from the monophenyl and mono tolyl hydrazines were phototropic. On the strength of this observation, they proposed a new type of isomerism in hydrazines (28):

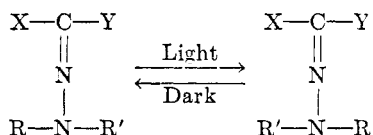

Such an isomerism, if it occurred, might account for the necessity for different substituents in a disubstituted hydrazone in order to form phototropic hydrazones. The known syn-anti isomerism would not account for this.

It then occurred to Graziani and Bovini to check up their theory by actually preparing hydrazones from disubstituted hydrazines in which the two substituents were different. They prepared a number of hydrazones from phenyl-benzyl hydrazone, phenyl-methyl hydrazone and phenyl- $\beta$ -naphthyl hydrazone. Not a one was phototropic (29). There being no longer any excuse for their first theory, Graziani and Bovini suggested two alternative mechanisms (29):

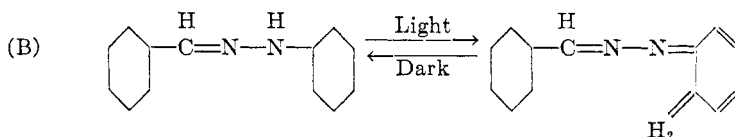
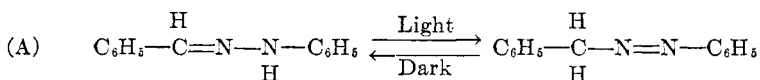

The authors preferred scheme "B," because they believed that this agreed best with the observation that no hydrazone derived from an aldehyde monosubstituted in an ortho position was phototropic. Just why the second ortho position could not react according to scheme B is not clear.

The first mechanism had already been proposed by Chattaway, and was discussed above. The second mechanism is safe from attack for the present since no one knows how to prepare the hypothetical product.

As a result of his studies upon the velocity of color change in both the light reaction and dark reaction of various phototropic substances, Padoa concluded that light produced a monomolecular reaction in salicylidene- $\beta$ -naphthylamine and benzaldehyde phenylhydrazone, and that the decolorizing reaction which took place in the dark with these substances was bimolecular.

From this evidence, Padoa believes that the phototropic change involves a polymerization and depolymerization, and that the weakly colored dark stable forms of salicylidene- $\beta$ -naphthylamine and benzaldehyde phenylhydrazone are the dimers of the more strongly colored light stable forms (73):

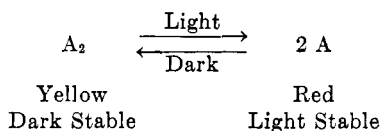

*Discussion.* While this paper is essentially a review, it may not be out of place to point out certain factors which have been implied in the work reviewed although they have not been specifically discussed by the various investigators.

In the present state of knowledge the distinction between a purely physical mechanism for phototropy and a purely chemical mechanism is not very clear, and is certainly unprofitable. It is a question if the mechanism proposed by Weigert could operate without involving what might be considered a change in chemical relationships, and on the other hand, a "purely chemical" photo-reaction is inconceivable.

The divergent views of the investigators has led to a certain

lack of coördination in the researches. The physical aspects of the phototropy of  $\beta$ -tetrachloro- $\alpha$ -ketonaphthalene have been most carefully investigated by Weigert, yet this substance has not been subjected to such investigations as those relating to the velocity of the color change which have been made to acquire some knowledge of the chemical relationships involved. On the other hand the anils, hydrazones and fulgides have not been given as careful a physical examination. Therefore, while a good deal of information is available on a variety of different substances, there is not the same breadth of information on any one substance or class of substances. As there is always the possibility that the mechanism is different in different cases, it is difficult to utilize the data available for the formulation of a complete theory, and the theories which have been proposed, or which could be proposed on the basis of the present knowledge, all suffer from this state of affairs.

It is generally agreed that the phototropy of these substances is bound up with the solid, if not definitely crystalline, state. In fact, these substances may be considered to form what might be called the pleochroic group. The name does not imply that other phototropic substances will not be found to be pleochroic, but that among the substances of this group the phototropism is known to be exhibited in an increased pleochroism of the crystals.

The very fact that the phototropic change manifests itself in an increased pleochroism of the crystals might at first sight seem to exclude the possibility of the change being due to the formation of a new colored compound, for it would be expected that light absorption due to molecular structure would be the same in all directions, whether or not the colored compound might be in solid solution in another substance. However, the situation is not so simple as it may at first appear. The distribution of the color throughout the phototropically excited crystal is not uniform, but the crystal becomes colored only where the light has acted. As was carefully pointed out by Wiegert, the phototropically excited crystal always shows some color change no matter in which direction it may be looked through. The change is much greater in one direction than in the others, but there is some changes along all of the axes.

Before it can be concluded that the substance of the crystal is always actually anisotropic as regards its light absorption it must be shown that the pleochroism of the excited crystals is not due to the distribution of the color in the crystal. This has not been done except with the chloronaphthalene compound. It is quite conceivable that when the excited crystal is looked at lengthwise, in which direction it shows the greatest color change, the light which passes through the crystal travels through the colored layers parallel to their surfaces, and, therefore, suffers the maximum absorption. When the crystal is looked at from the side, the light may pass through the colored layers perpendicular to their surfaces, and, therefore, through the least possible amount of colored material.

Even if it were shown that no new colored compound were formed in the phototropic reaction, it would not necessarily follow that the reaction was independent of the formation of a new substance. The photochemical production of a new compound within a photosensitive crystal is known to produce mechanical strains (65), which would seem to be similar in many respects to the strains pictured by Weigert as the cause of the color change. Such a mechanism would reconcile the evidences of chemical reaction accompanying the phototropic change with a physical picture similar to that proposed by Weigert.

In point of fact, there is no direct evidence of the formation of new substances as the result of the action of light on these phototropic materials, or of the "electrochromism" postulated by Weigert or "piezochromism" suggested above. The whole problem needs further investigation by the combined methods and view points of physics and chemistry. It would seem that the alchemistic axiom, "*corpora non agunt nisi liquida,*" would have to be forgotten for this work and the reactions investigated in the solid phase since they do not appear to occur in liquids; but phototropy furnishes an interesting field for investigation by the chemist who is interested in solid phase reactions. The purely physical investigation would seem to lie along more familiar lines, since if the light produced distortion of the electronic orbits within a crystal can cause color, it should be possible to

produce the distortion and color change by other agencies than light. In fact, it has already been found that the color change can be produced in salicylidene- $\beta$ -naphthylamine by rapid crystallization from solution (103), though whether this can be considered an instance of distorted crystal forces is open to question.

## REFERENCES

- (1) AMADUZZI, L., AND PADOA, M., Mem. accad. Bologna, (6) **8**; Nuovo cimento, **3**, 41-50 (1912); C. A., **6**, 1253 (1912).
- (2) ARIGA, T., Bull. Chem. Soc. Japan, **2**, 65-73 (1927).
- (3) BASS, L. W., AND BAUDISH, O., Science, **57**, 699 (1923).
- (4) BAUDISH, O., AND BASS, L. W., Ber., **55B**, 2698-2706 (1922).
- (5) BERE, C. M., AND SMILES, S., J. Chem. Soc., **125**, 2359-2363 (1924).
- (6) BILTZ, H., Ann., **305**, 170 (1899).
- (7) BILTZ, H., Z. physik. Chem., **30**, 527-528 (1899).
- (8) BILTZ, H., AND WIENANDS, Ann., **308**, 1-17 (1899).
- (9) BLASS, J., AND CZERWAK, P., Physik. Z., **5**, 363-368 (1904).
- (10) BOVINI, F., Atti accad. Lincei, **22** II, 460-465 (1913); C. A., **8**, 1275 (1914).
- (11) BRICKWEDDE, F. G., J. Optical Soc. Am., **14**, 312-322 (1927).
- (12) CAWLEY, J., Chem. News., **63**, 88 (1891).
- (13) CHANCEL, M. G., Compt. rend., **96**, 1469 (1883).
- (14) CHATTAWAY, F. D., J. Chem. Soc., **89**, 462-467 (1906).
- (15) CHILD, R., AND SMILES, S., J. Chem. Soc., **1926**, 2696-2702.
- (16) DAFERT, F. W., AND MIKLAUZ, R., Monatsh., **33**, 63-69 (1912).
- (16A) DE FAZI, REMO, Gazz. chim. Ital., **54**, 85-88 (1924).
- (17) DEY, M. L., Nature, **112**, 240 (1923).
- (18) DURST, G., Z. angew. Chem., **35**, 709 (1922).
- (19) DÜNNHAUPT, Dissertation Leipzig, 1914; see also ref. No. 114.
- (20) FISCHER, E., Ann., **190**, 135 (1877).
- (21) FISCHER, E., AND FISCHER, O., Ann., **194**, 274 (1878).
- (22) FORESTI, B., Atti accad. Lincei, (5) **23** II, 270-276 (1914); C. A., **9**, 1474 (1915).
- (23) FORMSTECHEK, F., Phot. Korr., **63**, 129-30 (1927).
- (24) GALLAGHER, P., Bull. soc. chim., (4) **29**, 683-696 (1921).
- (25) GALLAGHER, P., Bull. soc. chim., (4) **29**, 961-76 (1921).
- (26) GRAZIANI, F., Atti accad. Lincei, **19** II, 190-193 (1910); C. A., **5**, 277 (1911).
- (27) GRAZIANI, F., Atti accad. Lincei, **22** I, 623-629 (1913); C. A., **7**, 3495 (1913).
- (28) GRAZIANI, F., AND BOVINI, F., Atti accad. Lincei, **22** I, 793-797 (1913); C. A., **7**, 3759 (1913).
- (29) GRAZIANI, F., AND BOVINI, F., Atti accad. Lincei, **22** II, 32-41 (1913); C. A., **8**, 77 (1914).
- (30) HANTZSCH, A., Ber. **40**, 1541 (1907).
- (31) HANTZSCH, A., AND OSSWALD, G., Ber., **33**, 278 (1900).
- (32) HAUSER, W., Dissertation, Heidelberg, 1913.
- (33) HEILBRON, I. M., HUDSON, H. E., AND HUISSH, DORIS M., J. Chem. Soc., **123**, 2273-2279 (1923).

- (34) HOLMES, E. O., JR., *J. Am. Chem. Soc.*, **44**, 1002-1008 (1922).
- (35) JANAKIRAM, A., AND RAGHAVA RAO. BH. S. V., *J. Sci. Assoc., Maharajah's Coll.*, **1**, 112-113 (1924).
- (36) JOFFE, L. C., Dissertation, Zurich, 1921.
- (37) KEENAN, G. L., *Chem. Reviews*, **3**, 95-111 (1926).
- (38) KOWALSKI, J., *Z. Electrochem.*, **14**, 474 (footnote) (1908).
- (39) LASAREFF, P., *Z. physik. Chem.*, **78**, 661 (1912).
- (40) LEHNER, V., *J. Am. Chem. Soc.*, **43**, 29-35 (1921).
- (41) LENARD, P., *Ann. Physik.*, **68**, 553-573 (1922).
- (42) LIFSCHITZ, J., *Ber.* **52B**, 1919-1926 (1919).
- (43) LIFSCHITZ, J., *Ber.* **58B**, 2434-2440 (1925).
- (44) LIFSCHITZ, J., AND JOFFE, L. C., *Z. physik. Chem.*, **97**, 426-444 (1921).
- (45) MAASS, E., AND KEMPF, R., *Z. angew. Chem.*, **35**, 609-611 (1922).
- (46) MAASS, E., AND KEMPF, R., *Z. angew. Chem.*, **36**, 293-297 (1923).
- (47) MARCKWALD, W., *Z. physik. Chem.*, **30**, 140-145 (1899).
- (48) MARCKWALD, W., AND DETTMER, H., *Ber.*, **35**, 296-302 (1902).
- (49) MELOCHE, V. W., Private Communication.
- (50) MILLER, W. J., *Ber.*, **43**, 2609-2613 (1910).
- (51) MOURELO, J. R., *Anales soc. espán. fís. quím.*, **1**, 346 (1903).
- (52) MOURELO, J. R., *Anales soc. espán. fís. quím.*, **3**, 40 (1905).
- (53) MOURELO, J. R., *Arch. sci. phys. nat.* (4) **25**, 15-25 (1906).
- (54) MOURELO, J. R., *Anales soc. espán. fís. quím.*, **10**, 231-45 (1913); *C. A.*, **7**, 3445 (1913).
- (55) MOURELO, J. R., *Compt. rend.*, **158**, 122-125 (1914).
- (56) MOURELO, J. R., *Compt. rend.*, **160**, 174-176 (1915).
- (57) MOURELO, J. R., *Chem. News.*, **120**, 289-91 (1920).
- (58) MOURELO, J. R., *Anales soc. espán. fís. quím.*, **20**, 139-145 (1922); *C. A.*, **16**, 4127 (1922).
- (59) MOURELO, J. R., *Anales soc. espán. fís. quím.*, **20**, 601-605 (1922).
- (60) O'BRIEN, W. J., *J. Phys. Chem.*, **19**, 113-144 (1915).
- (61) ORR, J. B., *Chem. News*, **44**, 12-13 (1881).
- (62) PABST, Dissertation, Leipzig, 1902.
- (63) PADOA, M., *Atti accad. Lincei.*, **18 I**, 694-699 (1909); *C. A.*, **4**, 1739 (1910).
- (64) PADOA, M., *Gazz. chim. Ital.*, **44**, 535-562 (1914); *C. A.*, **9**, 1318 (1915).
- (65) PADOA, M., *Atti accad. Lincei.*, **28 II**, 372-377 (1919); *C. A.*, **14**, 2132 (1920).
- (66) PADOA, M., AND BOVINI, F., *Atti accad. Lincei*, **20 II**, 712-717 (1911); *C. A.*, **6**, 992 (1912).
- (67) PADOA, M., AND FORESTI, B., *Atti accad. Lincei*, **22 II**, 576-579 (1913); *C. A.*, **8**, 1368 (1914).
- (68) PADOA, M., AND FORESTI, B., *Atti accad. Lincei*, **23 I**, 95-98 (1914); *C. A.*, **8**, 2098 (1914).
- (69) PADOA, M., AND GRAZIANI, F., *Atti accad. Lincei*, **18 II**, 269 (1909); *C. A.*, **4**, 2296 (1910).
- (70) PADOA, M., AND GRAZIANI, *Atti accad. Lincei*, **18 II**, 559-564 (1909); *C. A.*, **4**, 2453 (1910).
- (71) PADOA, M., AND GRAZIANI, F., *Atti accad. Lincei*, **19 I**, 489-495 (1910); *C. A.*, **4**, 2453 (1910).

- (72) PADOA, M., AND GRAZIANI, F., *Atti accad. Lincei*, **19 II**, 193-196 (1910); *C. A.*, **5**, 277 (1911).
- (73) PADOA, M., AND MINGANTI, TERESA, *Atti accad. Lincei*, **22 II**, 500-505 (1913); *C. A.*, **8**, 1368 (1914); **9**, 1144 (1915).
- (74) PADOA, M., AND SANTI, L., *Atti accad. Lincei*, **19 II**, 302-307 (1910); *C. A.*, **5**, 277 (1911).
- (75) PADOA, M., AND SANTI, L., *Atti accad. Lincei*, **20 I**, 675-680 (1911); *C. A.*, **5**, 3404 (1911).
- (76) PADOA, M., AND SANTI, L., *Atti accad. Lincei*, **20 II**, 192-196 (1911); *C. A.*, **6**, 3272 (1912).
- (77) PADOA, M., AND SANTI, L., *Atti accad. Lincei*, **20 II**, 196-200 (1911); *C. A.*, **5**, 3809 (1911).
- (78) PADOA, M., AND TABELLINI, G., *Atti accad. Lincei*, **21 II**, 188-192 (1912); *C. A.*, **6**, 3219 (1912).
- (79) PADOA, M., AND ZAZZARONI, A., *Atti accad. Lincei*, **24 I**, 828-835 (1915); *C. A.*, **9**, 3066 (1915).
- (80) PADOA, M., AND ZAZZARONI, A., *Atti accad. Lincei*, **25 I**, 808-811 (1916); *C. A.*, **11**, 796 (1917).
- (81) PEUCKERT, PAUL, AND SIEGEL, HERBERT, Unpublished researches referred to in reference No. 114.
- (82) PHIPSON, T. L., *Chem. News*, **43**, 283 (1881).
- (83) PHIPSON, T. L., *Chem. News*, **44**, 73 (1881).
- (84) RAM, A. J., *J. Sci. Assoc., Maharajah's Coll.*, **1**, 110-111 (1924).
- (85) RAY, P. C., *J. Chem. Soc.*, **111**, 101-109 (1917).
- (86) REUTT, C., AND PAWLEWSKI, B., *Anz. Ak. Wiss., Krakau*, **1903**, 502; *Chem. Zentr.*, **1903 II**, 1432.
- (87) RUSSELL, W. J., *Proc. Roy. Soc. (London)*, **B80**, 376-387 (1908).
- (88) SANTI, L., *Atti accad. Lincei*, **20 II**, 228-30 (1911); *C. A.*, **6**, 83 (1912).
- (88A) SANYAL, A. K., AND DHAR, N. R., *Z. anorg. allgem. Chem.*, **128**, 212-217 (1923).
- (89) SCHLEEDE, A., *Z. physik. Chem.*, **106**, 386-398 (1923).
- (90) SCHLEEDE, A., AND HERTER, M., *Z. Electrochem.*, **29**, 411 (1923).
- (91) SCHLENK, W., AND HERZENSTEIN, A., *Ber.*, **43**, 3541-3546 (1910).
- (92) SCHMIDT, J., AND LUMPP, H., *Ber.*, **41**, 4215-4225 (1908).
- (93) SCHOENBURG, C., *Dissertation, Leipzig*, 1913.
- (94) SENIER, A., *Chem. News*, **106**, 163 (1912).
- (95) SENIER, A., AND CLARKE, ROSALIND, *J. Chem. Soc.*, **99**, 2081-2084 (1911).
- (96) SENIER, A., AND CLARKE, R., *J. Chem. Soc.*, **105**, 1917-1925 (1914).
- (97) SENIER, A., AND FORSTER, R. B., *J. Chem. Soc.*, **105**, 2462-2471 (1914).
- (98) SENIER, A., AND FORSTER, R. B., *J. Chem. Soc.*, **107**, 452-459 (1915).
- (99) SENIER, A., AND FORSTER, R. B., *J. Chem. Soc.*, **107**, 1168-1173 (1915).
- (100) SENIER, A., AND GALLAGHER, P., *J. Chem. Soc.*, **113**, 28-35 (1918).
- (101) SENIER, A., AND SHEPHEARD, F. G., *J. Chem. Soc.*, **95**, 441-445 (1909).
- (102) SENIER, A., AND SHEPHEARD, F. G., *J. Chem. Soc.*, **95**, 1943-1955 (1909).
- (103) SENIER, A., AND SHEPHEARD, F. G., CLARKE, R., *J. Chem. Soc.*, **101**, 1950-1958 (1912).
- (104) SHEPPARD, S. E., *Chem. Reviews*, **4**, 319-355 (1927).
- (105) SINGH, B. K., *J. Am. Chem. Soc.*, **43**, 333-334 (1921).

- (106) SINGH, B. K., *Quart. J. Indian Chem. Soc.*, **1**, 45-90 (1924).  
(107) SINGH, G., *J. Chem. Soc.*, **121**, 782-785 (1922).  
(108) SKRABAL, A., *Ber.*, **47**, 117-119 (1914).  
(109) STOBBE, H., *Ber.*, **37**, 2236-2240 (1904).  
(110) STOBBE, H., *Ber.*, **40**, 3372-3382 (1907).  
(111) STOBBE, H., *Ann.*, **359**, 1-48 (1908).  
(112) STOBBE, H., *Z. Electrochem.*, **14**, 473-483 (1908).  
(113) STOBBE, H., *Ann.*, **380**, 1-129 (1911).  
(114) STOBBE, H., *Ber. Verhandl. sächs, Akad. Wiss. Leipzig. Math. Phys., Klasse*, **74**, 161-250 (1922).  
(115) STOBBE, H., AND MALLISON, H., *Ber.*, **46**, 1226-1238 (1913).  
(116) STOBBE, H., AND NOWAK, R., *Ber.*, **46**, 2887-2902 (1913).  
(117) TER MEER, E., *Ann.*, **181**, 1-22 (1876).  
(118) THORMANN, K., Unpublished researches mentioned by Stobbe in Reference no. 114; See also Dissertation, Leipzig, 1912.  
(119) TRAUTZ, M., *Z. wiss. Phot.*, **4**, 351-359 (1906).  
(120) VAN AUBEL, E., *Compt. rend.*, **138**, 961-963 (1904).  
(121) VARAHALU, T., *J. Sci. Assoc., Maharajah's Coll.*, **1**, 107-110 (1924).  
(122) VENKATARAMAIAH, Y., AND RAO, B. S. V. R., *Nature*, **111**, 775 (1923).  
(123) VENKATARAMAIAH, Y., AND RAO, B. S. V. R., *J. Sci. Assoc., Maharajah's Coll.*, **1**, 41-44 (1923).  
(124) VENKATARAMAIAH, Y., AND JANAKIRAM, A., *J. Sci. Assoc., Maharajah's Coll.*, **2**, 16-18 (1924).  
(125) VILLIGER, V., AND KOPETSCHNI, E., *Ber.*, **45**, 2910-2922 (1912).  
(126) WALTHER, R., *J. prakt. Chem.*, **67**, 445-472 (1903).  
(127) WEIGERT, F., *Z. Elektrochem.*, **23**, 357-368 (1917).  
(128) WEIGERT, F., *Z. Elektrochem.*, **24**, 222-237 (1918).  
(129) WEIGERT, F., KAUFFMAN, AND MARCKWALD, W., *Z. Elektrochem.*, **24**, 381 (1918) (Discussion of No. 128.)  
(130) WEISER, H. B., AND GARRISON, A. D., *J. Phys. Chem.*, **31**, 1237-1245 (1927).  
(131) WILSON, F. J., HEILBRON, I. M., AND SUTHERLAND, MAGGIE, *J. Chem. Soc.*, **105**, 2892-2906 (1914).  
(132) ZANELLA, *Gazz. chim. ital.*, **54**, 247-50 (1924); *C. A.*, **18**, 3547 (1924).  
(133) ZINCKE, F., *Ber.*, **21**, 1040-1041 (1888).